

Electric power instead of oil



SERAC[®] electric cylinder
ASCA servo screw

Increase productivity. Reduce energy costs.

Drive systems

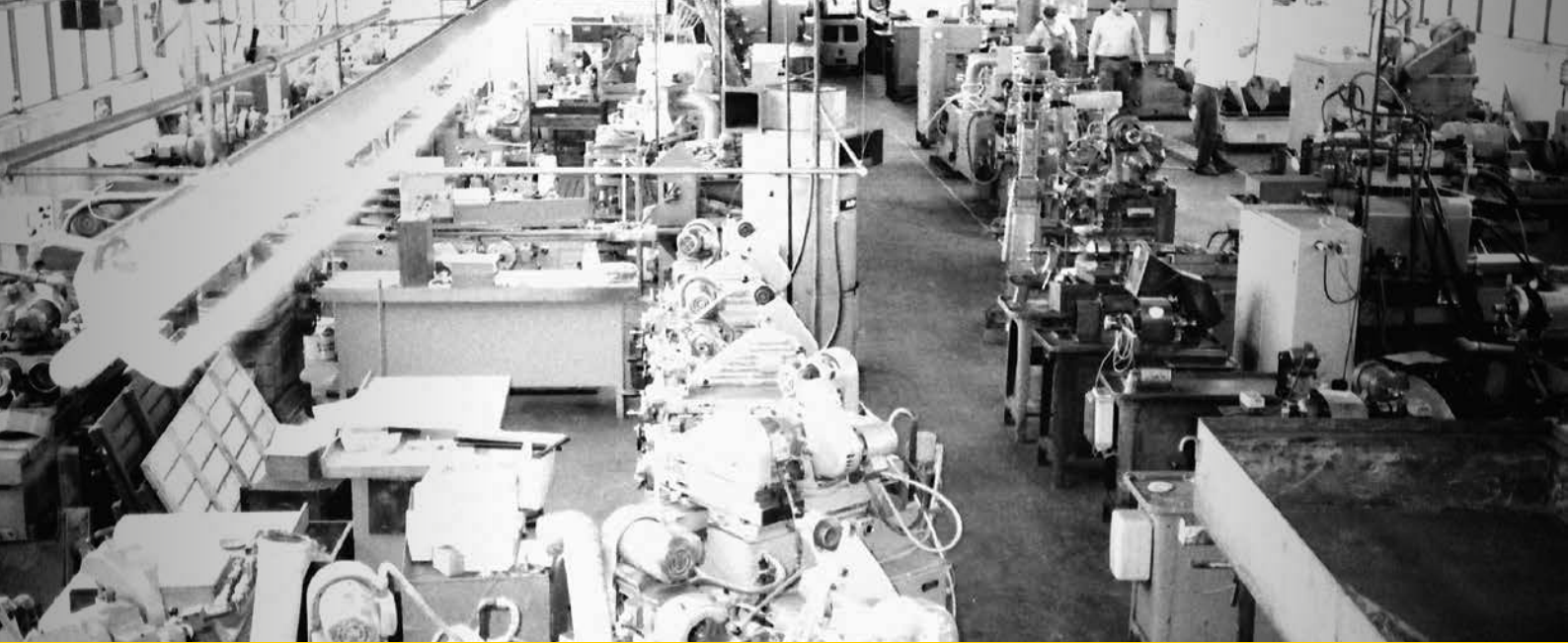

Precision made in Germany. Innovation since 1911.

Being close to our customers has always been and remains the basis of our corporate culture in the product sectors of clamping and drive technology.

Our international clientele benefits from the ongoing development of the company's expertise with the aim of assuring greatest possible satisfaction of current and future market needs. However, Ortlieb not only reacts to

the expectations of the market but has regarded itself as an innovation driver throughout the company's history. Since the turn of the millennium we have steadily developed the initially purely mechanical planet roller drive into the completely redesigned SERAC® servo linear drive family, including all control and measuring equipment, thus delivering perfect proof of the pioneering spirit at Ortlieb.

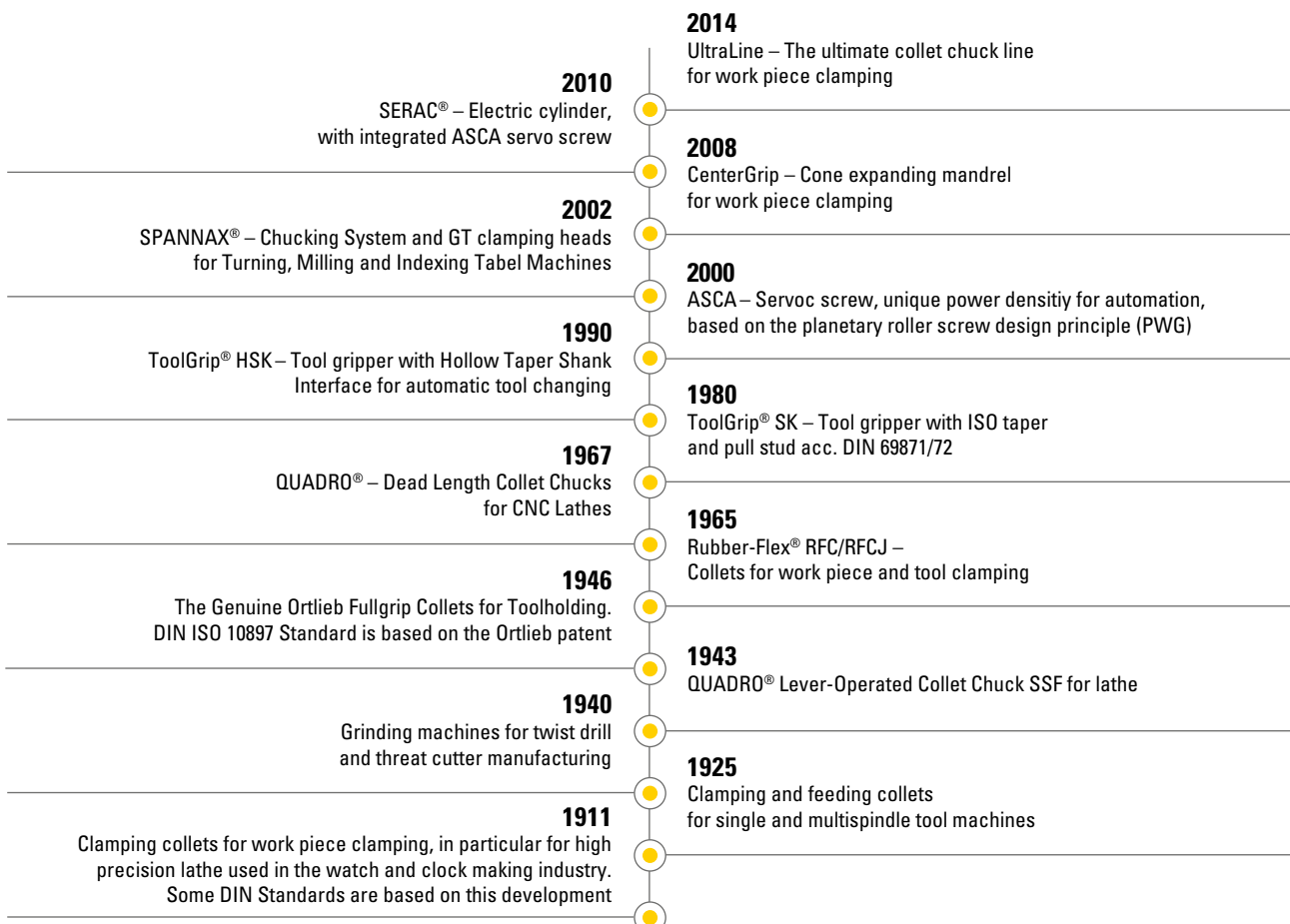



Then and now ...

Throughout its history, Ortlieb has regarded itself as a company which has stood out from the rest as a result of a wide range of pioneering product innovations. But Ortlieb is not resting on its laurels, today the company is already thinking of the future and making long-term strategic decisions.

To ensure it is properly armed for the future so that it can continue to play an innovative and leading role in the market, Ortlieb is investing in an innovative company building, including a production facility, which will set new stan-

dards in clamping and drive technology. The new production systems will enable Ortlieb to meet rising customer demands in terms of quality, flexibility, individuality and reduced lead times without any problem.

Ortlieb even plays a pioneering role in architecture and technical equipment. The company's new building is the most modern industrial building ever built in Baden-Württemberg in terms of energy efficiency – typically Ortlieb.

Ortlieb Services



Commissioning service

After mechanical installation by the customer, this service includes on-site support for the actual commissioning procedure. The final settings and the parameterisation of the Ortlieb components will be made to ensure top efficiency.

The controller is tuned when your machine is already operating but you have reached the limits using the standard settings. We make improvements and complete the final settings to suit your requirements.



Lease purchase

Would you like to test our electric drive systems before you buy? No problem with Ortlieb. With our lease purchase scheme you can get the product you need from us with no risk to yourselves for up to 4 weeks on lease.

If you decide against our solution, you only have to pay the lease costs for the relevant period. If you purchase it the lease costs will be set off against the purchase price. A fair solution.



Increase productivity. Reduce energy costs.

Ortlieb has proved that there is no contradiction in this with its electric drive systems. Increasing pressure from competitors, efficiency in production, improving productivity whilst retaining top quality and new statutory environment regulations are just some of the parameters which confront our customers every day. With electric drive systems from Ortlieb you are ideally equipped to face these challenges since electric drive systems deliver a whole series of benefits compared to hydraulic drive systems.

They are green because they do not need any oil, they are very quiet which enables the machine operator to produce more efficiently and above all they are more productive than hydraulic drive systems. Short setting times, reduced maintenance and a long service life even with small gradients and faster production times due to their design are clear benefits which cannot be dispersed. Find out more about the benefits and how you can reduce your energy costs by up to 80%. Contact us. We will gladly give you all the advice you need.



Faster

Shorter cycle time, fast positioning using direct drive equipment, no vibration in control circuit.



More efficient

Energy costs can be reduced by up to 80% compared to hydraulic drive systems.



Quieter

Electrical drive systems from Ortlieb are very quiet – your workforce will thank you.



More durable

High quality standards and our own production facility made in Germany guarantee top-class quality and a long service life.























Look into the future with Ortlieb.

Electrical drive systems from Ortlieb are at home in almost every industry and contribute to the technical progress of our society. For example, research is being carried out in space using electrical drive systems from Ortlieb. The precise adjustment of Ortlieb drive systems has made new insights possible.

Industry expertise

 Automotive industry	 Railway engineering	 Machine tools	 Steel industry	 Aerospace
 Measuring equipment	 Test equipment	 Medicine	 Plastics technology	 Packaging industry
 Special plant and machine production	 Offshore	 Textile industry	 Agricultural and construction machinery	 Wind power
 Building engineering	 Solar industry	 Paper industry	 Food industry	 Electrical industry



Maximum performance – Always more than you expect

For Ortlieb, the PRECISION COMPANY, innovation, quality and precision have a long tradition. Everyday customer proximity has been and remains the basis for economic and precise solutions in drive and clamping technology.

Ortlieb customers benefit from the concentrated, continuous further advancement of its development and manufacturing expertise aimed at the greatest possible customer benefit.

But Ortlieb does not just react to the demands of the market, we also offer innovative momentum. The development of the planetary roller screw to the industrially usable production ASCA servo screw is an example of our pioneering spirit and willingness to convince. Often, this will open up completely new possibilities.

MADE IN GERMANY is the quality guarantee of Ortlieb. It goes right through from the basic technical development to the hardware delivered. A highly efficient production structure is the basis for the marketability of innovative products which are manufactured in Germany with good reason.

Realisierte Sonderlösung

Die Herausforderung bei diesem Projekt war es, das Produktportfolio des Kunden um eine elektrische Presse zu erweitern. Hierbei zählten für den Kunden die Vorteile der Ortlieb Elektrozyylinder – diese gewährleisteten einen schnelleren, leiseren und langlebigeren Betrieb und können dabei bis zu 80 % Energiekosten gegenüber hydraulischen Antriebssystemen einsparen. Gemeinsam mit dem Kunden betreute Ortlieb dabei die Entwicklung von den ersten Machbarkeitsstudien über die Produktion der ersten Prototypen bis hin zum fertigen Serienprodukt.

Mit Leistungswerten von:

- 300 kN maximale Presskraft
- Mehr als 50 kW Leistung
- Einer maximalen Geschwindigkeit von 300 mm/s im Eiltempo
- Einer Beschleunigung von bis zu 6,7 m/s²
- Einem Hub von 200mm
- eines integrierten Wasserkühlkreislauf
- Positionierungs- und Wiederholgenauigkeit von +/- 0,001 mm

erfüllte Ortlieb dabei alle Wünsche des Kunden und fertigte ein Lösung die exakt nach den Bedürfnissen des Kunden.



Concentration on the essentials leads to outstanding results

Drive systems

Für Anwendungen, die bisher auf hydraulische Antriebe angewiesen waren, gibt es jetzt durch Ortlieb eine echte Alternative. Die ASCA Servospindel kombiniert die Funktionen eines Planetengetriebes mit denen einer Linearspindel. Grundlage dazu ist die Technologie der Planeten-Wälz-Gewindespindel (PWG). Die ASCA Servospindel ist die Technologiebasis der SERAC® Elektrozyylinder.

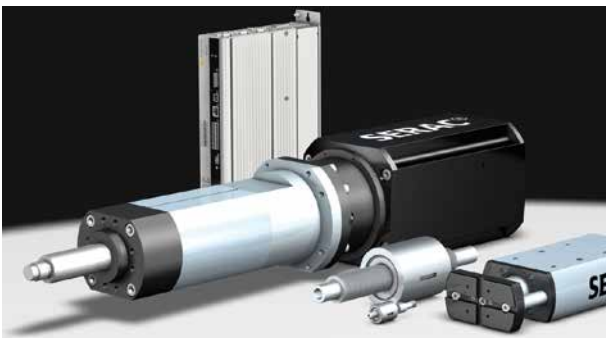

Clamping systems

Since 1911 we have stood for innovative and extremely reliable solutions in workpiece and tool clamping. Whether you need standard collet chucks or manufacture of special clamping devices to specification – the benefit of our extensive know-how is at your service.





Drive systems with maximum power density

With the ASCA servo screw, a genuine alternative now exists for applications which until now have been dependent on hydraulic drives. The basis is the technology of the PWG planetary roller screw. The ASCA servo screw is the technological basis of the SERAC® electric cylinders.

Contents

ASCA servo screw	
Introduction	Page 4
The functional principle	Page 6
Technological characteristics	Page 8
Standard version or customer design	Page 10
Data and screw nut dimensions (standard)	Page 12
Model codes	Page 14
Customer design information	Page 15
Application calculations	Page 16
SERAC® electric cylinders	
Introduction and system advantages	Page 18
Summary of range	Page 20
SERAC® XH	
Short profile	Page 22
Performance data and screw leads	Page 24
Model codes, dimensions and stroke lengths ..	Page 25
SERAC® XHM	
Short profile	Page 26
Performance data	Page 28
Model codes, dimensions and stroke lengths ..	Page 29
SERAC® KH	
Short profile	Page 30
Performance data and screw leads	Page 32
Model codes, dimensions and stroke lengths ..	Page 33
SERAC® LH	
Short profile	Page 34
Performance data	Page 36
Screw leads	Page 37
Model codes	Page 38
Dimensions and stroke lengths	Page 39
ServoOne servo controller	
Short profile	Page 40
Software and peripherals	Page 41

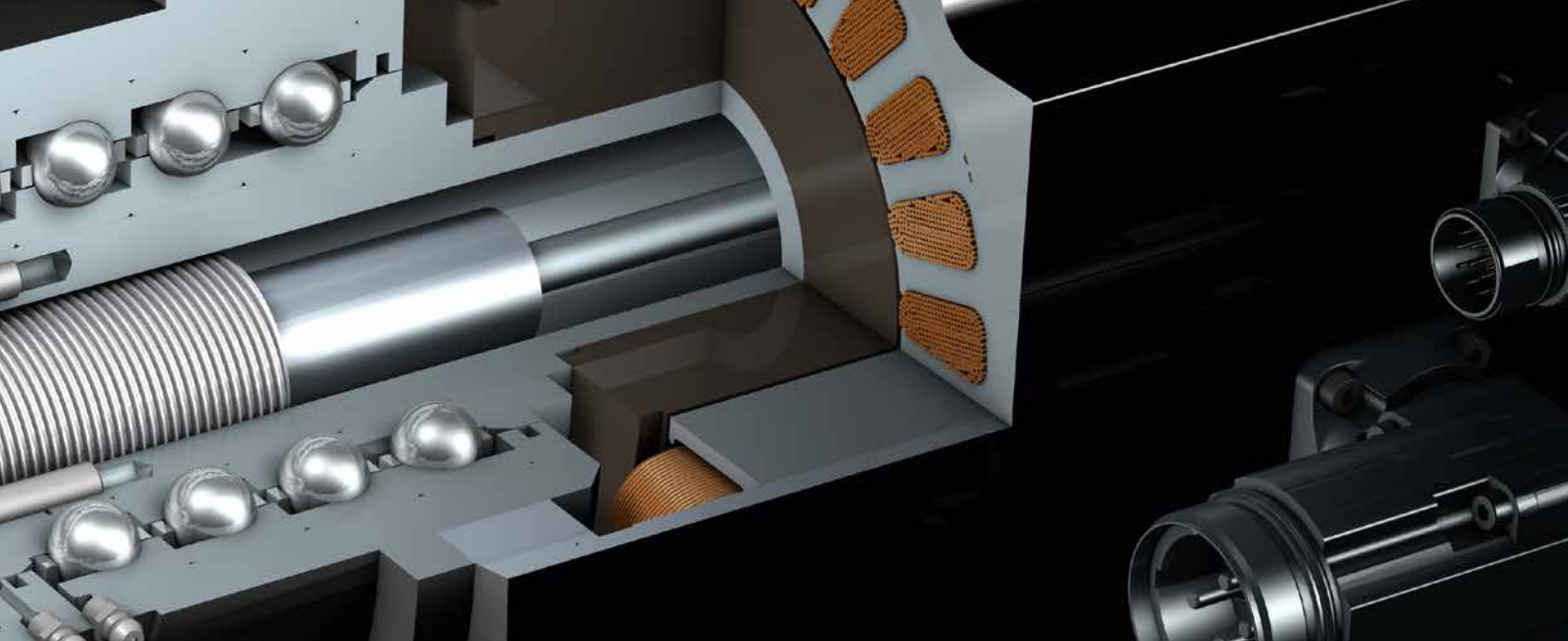

ASCA servo screw

The ASCA servo screw combines the functions of a planetary gear unit with those of a screw. The merging of these two functions leads to a considerable reduction in the space and weight of a drive axis.



ASCA servo screw PWG 10 and PWG 100

SERAC® electric cylinders

These fully redesigned servo linear drives utilize the many benefits of the ASCA servo screw. A typical example of the many advantages of the SERAC® electric cylinders is their high dynamics. They are increasingly replacing previous hydraulic solutions in many applications.



SERAC® LH100, XH12, KH30 and servodrive ServoOne



SERAC® XHM
This screw unit fits any servo motor

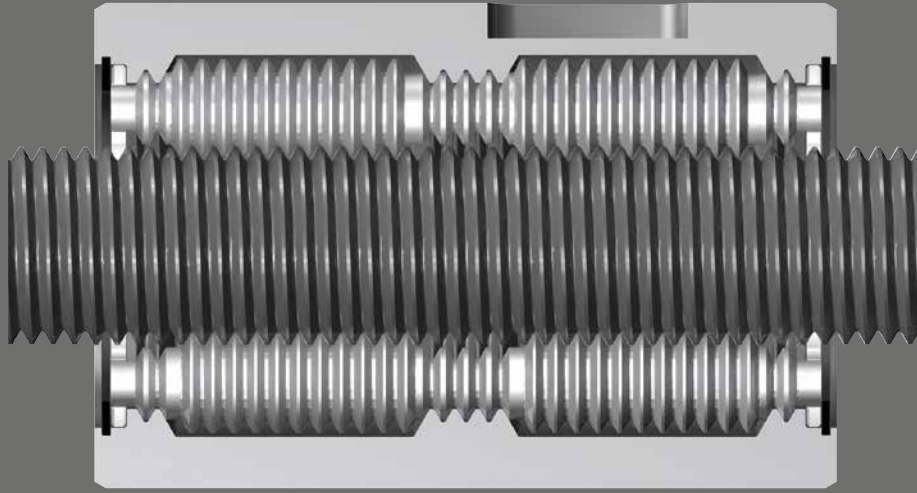

ASCA servo screw – unique power density for automation

The ASCA servo screw is based on the PWG planetary roller screw design principle. This new screw technology converts the rotary motion of a motor directly into linear motion.

The dimensions of the ASCA servo screw can be extremely compact in form considering the force achieved. Because the reduction of a planetary gear unit is part of its functionality, the motor connection can be made directly without additional gears.

With its compact size and the potential for reaching very high forces and rapid motion with small motors, the ASCA servo screw follows the trend in mechatronics towards compact, efficient solutions.

Drive technology from space travel ...

Development background

The German Aerospace Center (DLR) developed the first remote-controlled robot for the D2 mission (1993).

The problem of meeting the strict weight limit while generating the required force could not be solved with conventional screw drives. Because of these conflicting requirements, the DLR decided to look for a completely new approach.

The project for this solution led to the development of the PWG planetary roller screw. The functional principle was patented worldwide by the DLR.

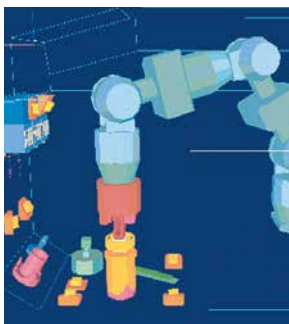

The industrial solution

Brilliant design is one thing, but turning it into an industrial-scale product that works reliably in all situations is quite another.

Wilhelm Narr GmbH & Co. KG, an Ortlieb sister company within the Narr group, acquired the licence from the DLR, recognising the great potential of the PWG planetary roller screw with its completely new functionality.

Initial tests under the most severe conditions met every expectation. The results were extremely promising. They provided the impetus to continue to develop the technology on an industrial scale, particularly in terms of production engineering and tribology.

With the merger of Narr and Ortlieb to form Ortlieb Präzisionssysteme GmbH & Co. KG, the well-known Narr servo screw was incorporated into the Ortlieb portfolio as the ASCA servo screw.

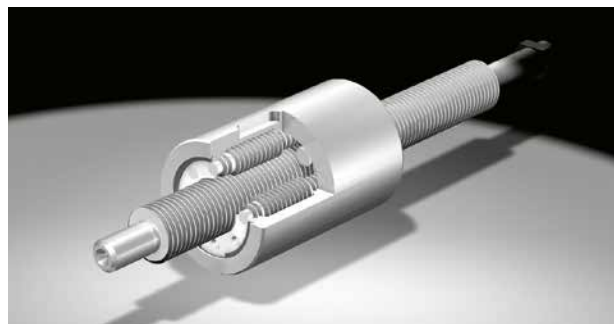

The functional principle ...

PWG Planetary roller screw

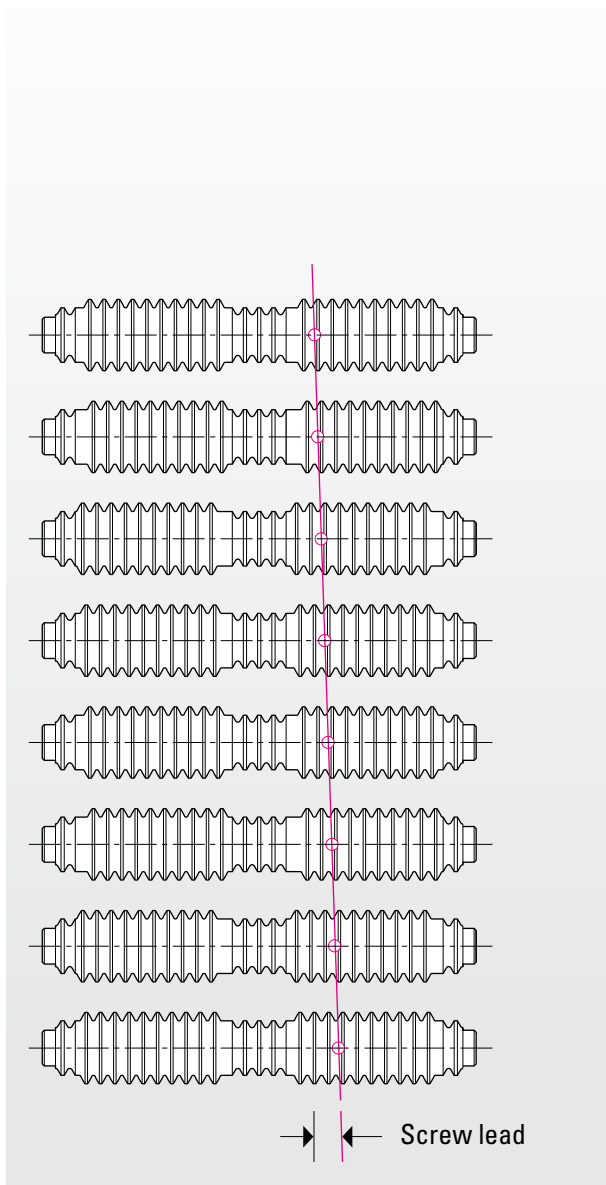

Power transmission can be through the screw shaft or the screw nut. The connection between nut and screw is formed by several rotating planetary rollers.

The transmission of the drive torque is by frictional locking. This causes low slip – which is not to be confused with backlash.

The planetary rollers with their circumferential drive grooves emulate the screw thread according to their various positions in the planet carrier.

As they orbit the screw as they spin, the screw is driven axially according to the direction of rotation. The large number of contact surfaces gives the structure high axial rigidity.

The system-related slip contributes to the robustness and durability because the contact points of the screw and planetary roller flanks change constantly, which prevents the parts being eroded. The level of slip depends on the application and is affected by factors like the direction and level of force, speed, acceleration, temperature, lubrication and other factors.

Example:

At maximum force slip of about 1 % must be allowed for. At 1 mm lead, for example, 19.80 mm travel is obtained at 20 revolutions. The slip can be compensated for by direct or indirect travel measurement. A positive feature is that the slip does not impact on the dynamic behaviour of a controlled drive axis.

The graphic (left) shows a developed view of the planetary rollers which in total represent a sort of internal thread. The axial displacement of the drive grooves is obtained from the screw lead.

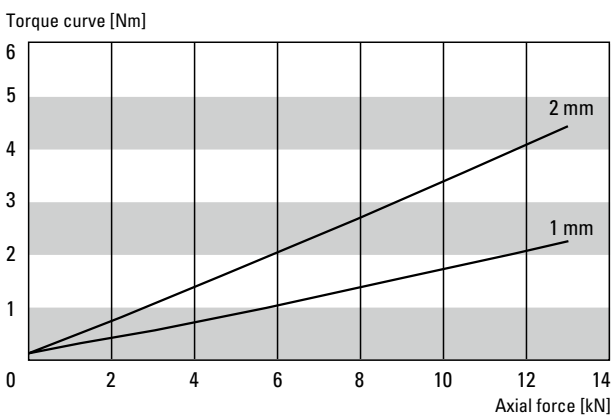
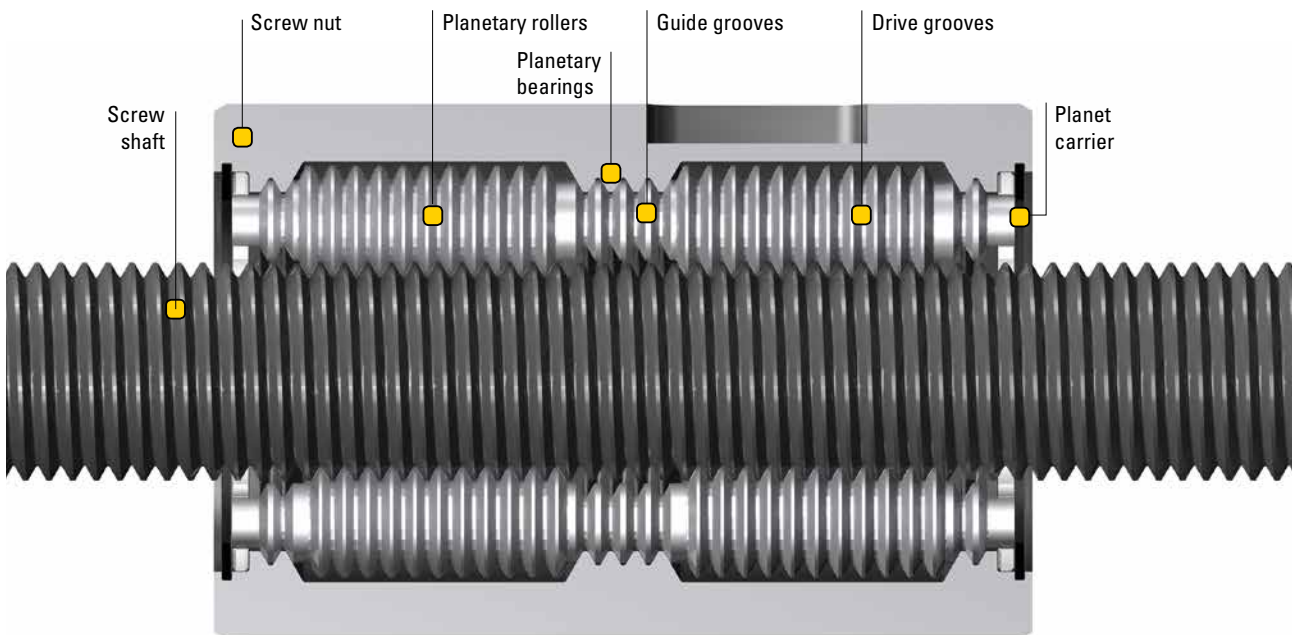

The diagram shows the driving torque required to generate a specific force (without allowing for the screw bearing).

Example: At 2 mm lead, torque of only 3.4 Nm is needed to generate 10 kN. At 1 mm lead this is reduced to 1.9 Nm.

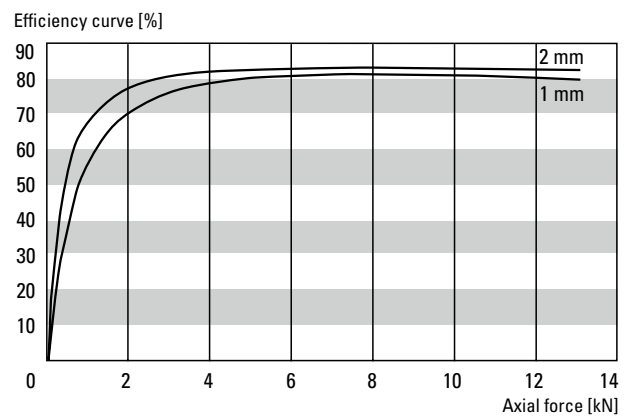

The diagram shows the efficiency curve of an ASCA servo screw with 1 mm and 2 mm lead.

It is clear that very high efficiency levels can be obtained even at small leads. Due to the preloading of the planetary rollers, the efficiency is relatively low in the lower force ranges but rises as the force increases.

ASCA servo screw – lead from 1 mm

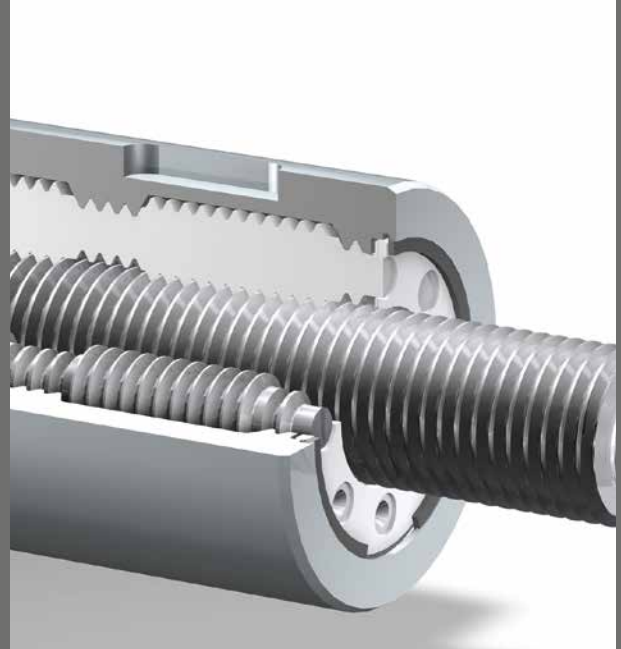

- High travel speeds
- High translation rates
- High efficiency
- High stability
and high load capacity
with minimal volume!

The combination of the “screw” and “planetary gear” principles gives great variability and optimization of the design. Under this principle an electric cylinder with an ASCA servo screw does not generally need an additional gear unit.

The specific advantages of this innovative construction include the ability to use a lead of only 1 mm without any problem. The result is very high translation rates and efficiency levels of up to 90 % are achieved despite the small lead. So small, lightweight motors can be used to generate very high forces.

The ASCA servo screw is ideally suited for dynamic drive solutions because it is backlash-free.

The translation ratio from rotational to linear motion can be set within wide limits by varying the screw lead.

The ASCA servo screw is suitable for both dynamic applications and creep movements.

High travel rates can be reached due to great high speed capability and the use of greater leads.

The ASCA servo screw is also superior to traditional ball and roller screw systems at short strokes.

Specific technological advantages for many different solutions

The versatile potential of the ASCA servo screw:

- Leads from 1 to 10 mm
- High translation rate
- High power density
- High load capacity
- High efficiency
- High dynamics
- High travel speed
- Long life
- Low noise
- Robust construction
- High rigidity
- No backlash

The ASCA servo screw offers the solution
for many different applications:

- Replacement of hydraulic and pneumatic cylinders
- Short cycle time
- Limited space application
- High force requirement
- High travel speed
- Extreme creep movement
- High dynamics
- Quiet running – without roller resetting
- Lightweight construction
- Short strokes
- Manufacturing from order quantities of one according to customers drawing
- Large-scale-production

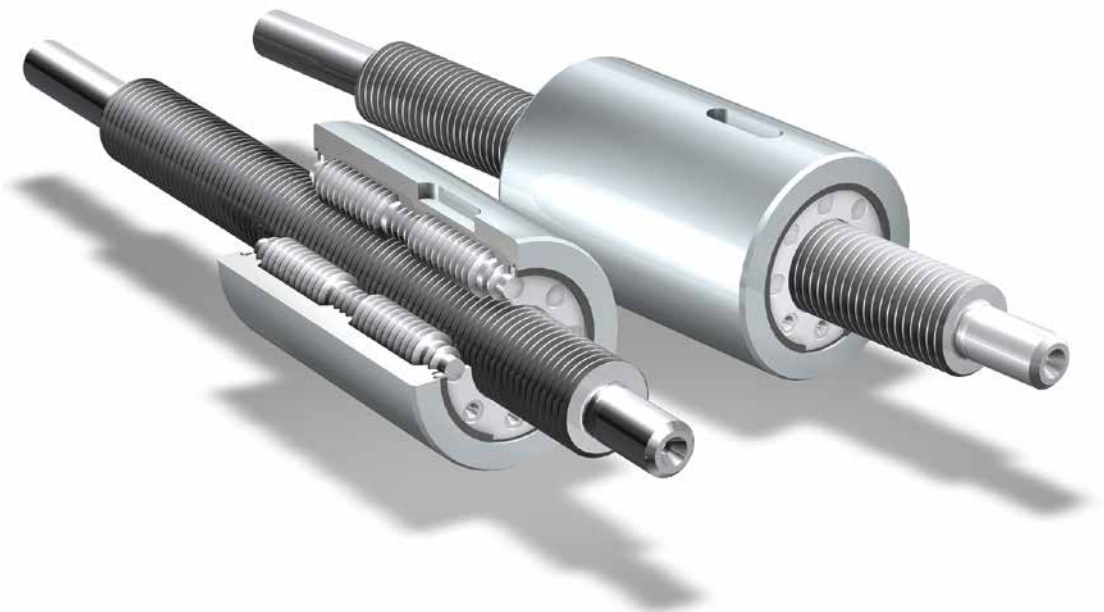

ASCA servo screw

– standard version or customer design

Suitable for series motors or integrated solutions

The standard ASCA servo screw series is available in ten sizes with different leads. The screw nut design comes in two different standard versions for different types of mounting.

As an alternative, the design flexibility of the ASCA servo screw offers the option of customized production of screw and nut.

It is also possible to create specialized screw drives. With its Customer Design, Ortlieb offers complete design of specific solutions with integrated motor – also non-standard. And from a batch size of one if required, to utilize the specific potential of the ASCA servo screw for special individual applications as well.

The Ortlieb Customer Design section specializes in customized screw drives for minimal, small and medium series production.



ASCA servo screw (PWG 16), standard version



ASCA servo screw (PWG 20) with sealed nut housing, non-standard version (customer design)

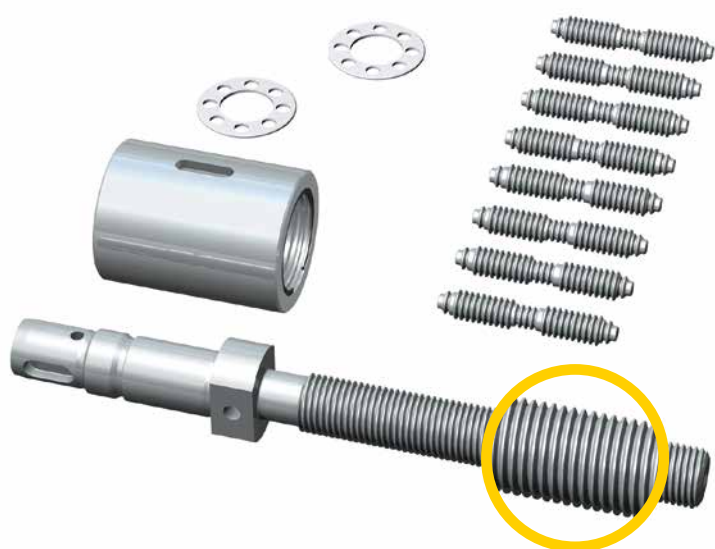

Precise and robust due to few components

The number of components in a PWG planetary roller screw is astonishingly low. Which makes the demand for production quality even higher. The two factors “few components” and “high precision” give high reliability and extreme robustness even with small leads.

Important: The ASCA servo screw operates without roller resetting, making it much quieter.

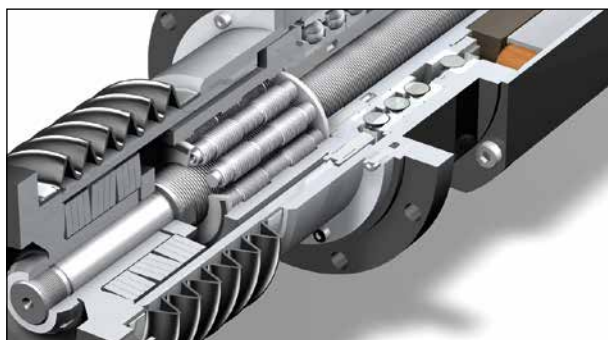

ASCA servo screw in customer design version with standard motor



ASCA servo screw in customer design version with non-standard motor

ASCA servo screw in standard version

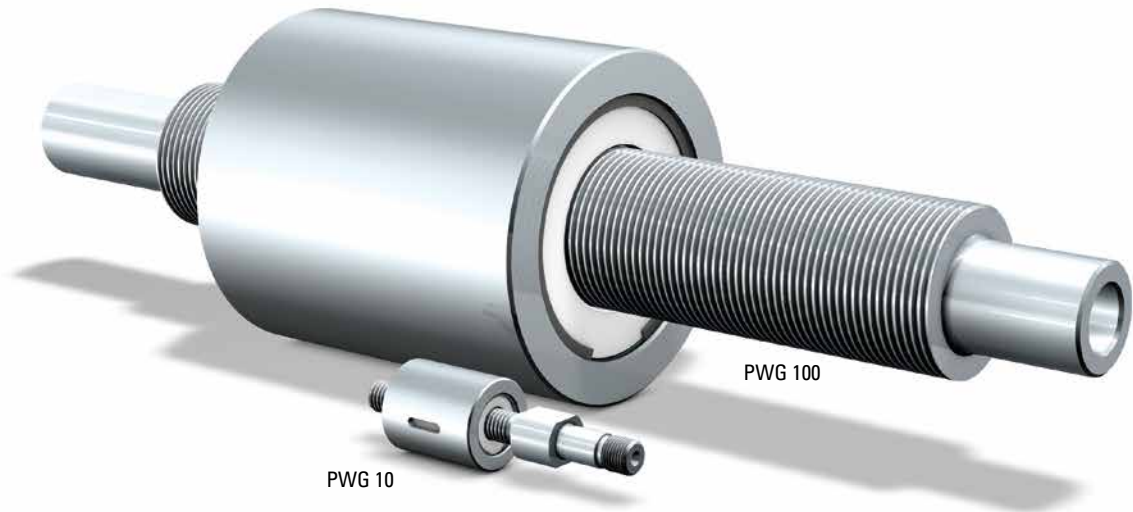

Series overview

Model	Lead						Rated-Ø screw d [mm]	max. force [kN]	Dynamic load rating C [kN]	maximum permitted speed ¹ n_{max} [U/min]	max. length of screwshaft ² L_{max} [mm]	maximum stroke ² S_{max} [mm]
	p [mm]											
PWG 10	1	2					9.4	4.5	8	14000	220	150
PWG 12	1	2					11.7	9	17	11660	250	170
PWG 16	1	2	3				15.7	12	26	8750	400	200
PWG 20	1	2	3	4			19.7	22	45	7000	500	300
PWG 25	1	2	3	4	5		24.7	30	60	5600	850	400
PWG 32	1.5	3	4.5	6			31.7	60	95	4370	850	400
PWG 44	1.5	3	4.5	6	7.5	9	43.4	100	200	3180	850	400
PWG 63	2	4	6	8	10	12	62.7	170	330	2220	850	400
PWG 73	3	6	9	12	15		72.6	210	420	1920	850	400
PWG 100	3	6	9	14.5	17.5	20.5	97.7	300	765	1750	850	400

¹ Higher speeds are only permitted after contacting Orlied

² On request we check the feasibility in detail



Screw nut (A1)
Cylindrical with keyway



Screw nut (A2)
With flange (flat sides)

Screw nut versions

Dimensions (cylindrical type)

Type: A1 cylindrical	Model	D g6	L1	L2	a	b	t	
	PWG 10 x..-A1	27	35	15	3	12	1.8	
	PWG 12 x..-A1	35	45.5	17	4	14	2.5	
	PWG 16 x..-A1	38	49	19	4	16	2.5	
	PWG 20 x..-A1	49	62	25	5	20	3	
	PWG 25 x..-A1	54	69.5	27.5	6	22	3.5	
	PWG 32 x..-A1	70	87	35	8	30	4	
	PWG 44 x..-A1	100	122	50	12	40	5	
	PWG 63 x..-A1	130	160			On request		
	PWG 73 x..-A1	155	190			On request		
	PWG 100 x..-A1	185	190			On request		

All dimensions in mm

Dimensions (flat-sided flange type)

Type: A2 flat-sided flange	Model	D1 g6	D2	D3	D4	L1	L2	L3	L4	N	W
	PWG 10 x..-A2	26	39	32.5	3.4	35	6	5	29	6	45°
	PWG 12 x..-A2	33	49	41	4.5	45.5	8	7	36	6	45°
	PWG 16 x..-A2	37	56	47	5.5	49	9	8.5	42	6	45°
	PWG 20 x..-A2	48	72	60	6.6	62	11	9.5	52	6	45°
	PWG 25 x..-A2	54	78	66	6.6	69.5	12	10	60	6	45°
	PWG 32 x..-A2	70	100	85	9	87	15	12	75	6	45°
	PWG 44 x..-A2	100	136	118	11	122	20	16	110	8	30°
	PWG 63 x..-A2	127	172	150	13.5	155	27	22	135	10	22.5°
	PWG 73 x..-A2	155	On request			160	On request				
	PWG 100 x..-A2	185	240	210	17.5	190	30	25	187	14	15°

All dimensions in mm

ASCA servo screw in standard version

Model codes/order data

Equipment parameter	Version specification	Order code	PWG 10	PWG 12	PWG 16	PWG 20	PWG 25	PWG 32	PWG 44	PWG 63	PWG 73	PWG 100
Screw lead	1 mm		1	1	1	1	1					
	1.5 mm							1.5	1.5			
	2 mm		2	2	2	2	2			2		
	3 mm				3	3	3	3	3		3	3
	4 mm					4	4			4		
	4.5 mm							4.5	4.5			
	5 mm						5					
	6 mm							6	6	6	6	6
	7.5 mm								7.5			
	8 mm									8		
	9 mm										9	9
	10 mm									10		
	11.5 mm											11.5
	12 mm										12	
	14.5 mm											14.5
	15 mm										15	
17.5 mm											17.5	
20.5 mm											20.5	
Nut type	Cylindrical	A	1	1	1	1	1	1	1	1	1	1
	Flat-sided flange	A	2	2	2	2	2	2	2	2	2	2

Sample order PWG 16 x 2 - A 1

Size
Screw lead
Nut type

ASCA servo screw with special adaptations

Do you need different mechanical interfaces or special performance characteristics?

We shall be pleased to check their feasibility. Send us your drawing or let's talk about your ideas. We will produce a proposal without commitment for you for a specially designed or adapted version.

Consultancy service

Because there are many design options for an ASCA servo screw, we generally recommend a discussion for preliminary clarification as early as possible. The potential of the ASCA servo screw can then be utilized to the full.

We look forward to your call to arrange a meeting at your facility. Tel.: +49 (0)7021 9469-50



Calculation of ASCA servo screw service life

The service life of ASCA servo screws follows an S-N (or Wöhler) curve with $k = 3$.

$$L_{10} = 10^6 \left(\frac{C}{F_A} \right)^3 \text{ revs.}$$

L_{10} Service life with 10 % probability of failure
 C Dynamic load rating
 F_A Equivalent load

Calculation of equivalent load F_A

1) Constant load

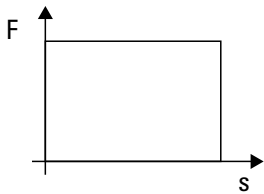

$$F_A = F$$

2) Increasing load

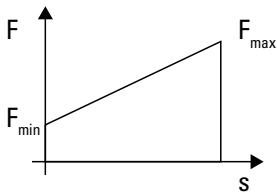

$$F_A = \frac{F_{Min} + 2F_{Max}}{3}$$

3) Load steps

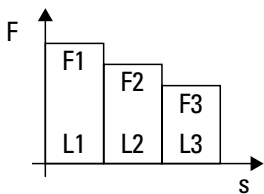

$$F_A = \sqrt[3]{\frac{\sum_{i=1}^m F_i^3 L_i}{\sum_{i=1}^m L_i}}$$

Sample calculation

The equivalent load and service life are determined for the following load profile:

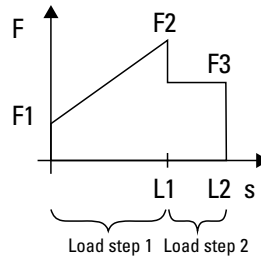

$F_1 = 1 \text{ kN}$
 $F_2 = 10 \text{ kN}$
 $F_3 = 5 \text{ kN}$

$L_1 = 15 \text{ mm}$
 $L_2 = 20 \text{ mm}$

Applicable to load step 1:

$$F_{A1} = \frac{F_1 + 2F_2}{3} = \frac{1 \text{ kN} + 2 \cdot 10 \text{ kN}}{3} = 7 \text{ kN}$$

Applicable to load step 2:

$F_{A2} = F_3 = 5 \text{ kN}$

Therefore for F_{A1ot} :

$$\begin{aligned} F_{A1ot} &= \sqrt[3]{\frac{F_{A1}^3 \cdot L_1 + F_{A2}^3 \cdot (L_2 - L_1)}{L_{21}}} \\ &= \sqrt[3]{\frac{(7 \text{ kN})^3 \cdot 15 \text{ mm} + (5 \text{ kN})^3 \cdot 5 \text{ mm}}{20 \text{ mm}}} \\ &= 6,6 \text{ kN} \end{aligned}$$

An ASCA servo screw PWG 16 with lead $p = 2 \text{ mm}$ is used.

The dynamic load rating is 26 kN.

The service life is calculated as follows:

$$L_{10} = 10^6 \left(\frac{26 \text{ kN}}{6,6 \text{ kN}} \right)^3 \text{ revs.} \approx 61.1 \text{ million revolutions}$$

At a stroke of $s = 35 \text{ mm}$ and a lead of $p = 2 \text{ mm}$, the ASCA servo screw makes 17.5 revolutions per stroke.

The service life in strokes is calculated as:

$$\frac{61.1 \text{ mill.}}{17.5} = 3.5 \text{ million strokes}$$

Calculation of motor torque and speed

Calculation of motor torque

The driving torque of the ASCA servo screw is calculated as follows:

$$M_{\text{PVG}} = \frac{p \cdot F_a}{2\pi \cdot \eta_{\text{PVG}}}$$

M_{PVG} Driving torque of ASCA servo screw
 p Lead
 F_a Axial force
 η_{PVG} Efficiency of ASCA servo screw

Calculation of holding torque

$$\text{Holding torque} = \frac{2\pi \cdot M}{p \cdot (2 - 1/\eta_{\text{PVG}})}$$

M^{Holding} Holding torque
 p Lead
 M^{Bremse} Torque to brake
 η_{PVG} Efficiency of ASCA servo screw

Sample calculation

At an axial force of $F = 14 \text{ kN}$, a screw lead of $p = 1 \text{ mm}$ and an efficiency of the ASCA servo screw of 85 %, the driving torque required for the ASCA servo screw is obtained as follows:

$$M_{\text{PVG}} = \frac{1 \text{ mm} \cdot 14 \text{ kN}}{2\pi \cdot 0.85^*} = 2.62 \text{ Nm}$$

The bearing friction must also be considered when designing the motor torque; it depends on the type of bearing and the lubrication.

More precise data should be requested from the bearing manufacturer.

In this example the bearing friction at 14 kN is approx. 0.5 Nm.

A required driving torque for the motor of approx. 3.12 Nm is obtained. Safety factors of 30-50 % should be considered when selecting the motor.

* Efficiency at rated load and a speed of $n = 200 \text{ rpm}$; lower efficiency can be expected at higher speeds due to the increasing grease friction

Calculation of motor speed

The motor speed is calculated as follows:

$$n = \frac{s}{p \cdot t_{\text{stroke}}}$$

s Stroke
 p Lead
 t_{stroke} Time in which the stroke s must be travelled

In the above example a stroke of approx. 10 mm should be completed in less than 0.5 s.

Without considering acceleration and braking, this gives:

$$n = \frac{s}{p \cdot t_{\text{stroke}}} = \frac{10 \text{ mm}}{1 \text{ mm} \cdot 0.5 \text{ s}} \cdot \frac{60 \text{ s}}{\text{min}} = 1200 \frac{1}{\text{min}}$$

The duration for acceleration and braking can only be calculated when the mass moment of inertia is known.

A required average speed for the motor of $n = 1200 \text{ rpm}$ is obtained.

A correspondingly higher maximum speed would result if acceleration and braking were included.

Speed limit

The following factor applies to the maximum speed limit of the ASCA servo screw:

$$d \cdot n < 140\,000$$

d ASCA servo screw nominal diameter in mm
 n Speed in rpm

Sample calculation

An ASCA servo screw PWG 44 is to be operated at a speed $n = 3000 \text{ rpm}$.

The nominal diameter is $d = 43.4 \text{ mm}$. This gives:

$$d \cdot n = 43.4 \text{ mm} \cdot 3000 \frac{1}{\text{min}} = 130\,200 < 140\,000$$

Therefore a speed of 3000 rpm is allowable for the ASCA servo screw.

Electric power instead of oil

SERAC® electric cylinder – with integrated ASCA servo screw

With the development of the SERAC® electric cylinder, all the technological advantages of an ASCA servo screw can be exploited in a complete series solution.

The direct power transmission of the ASCA servo screw (without additional reduction gears) and the smooth motion without roller resetting provide a range of unique selling points (page 21).

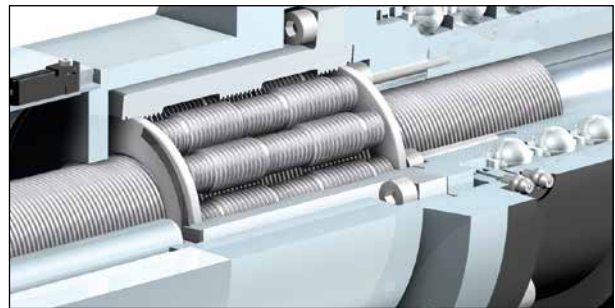



Ultra compact models with high power density for limited space applications

With the high control quality of the backlash-free ASCA servo screw, applications with very short cycle times are possible.

So SERAC® electric cylinders are suitable for many different uses as a clean alternative to hydraulic cylinders.

With the typical slimline design of the SERAC® electric cylinders, it is possible in many cases to replace the hydraulic cylinders in existing systems.

Typical applications



Joining



Punching



Bending



Forming



Powder pressing



Dynamic adjustment



Plastic moulding

The specific SERAC® system advantages offer new options for many different applications

- Maximum power density due to small screw leads
- Screw lead selectable in 1 mm steps, so good adaptability to the application
- Direct power transmission of the ASCA servo screw without additional gears, so good variability and high dynamics
- Long life through the use of a heavy duty screw drive with many force transmission points
- No axial backlash
- ASCA servo screw subject to slip, so long life even with short strokes
- Integrated linear travel measurement system for maximum positioning accuracy under load
- Low noise through the use of the ASCA servo screw without roller resetting
- Made in Germany

Complete solutions ready for connection

SERAC® XH

The slimline design largely corresponds to a hydraulic cylinder, so that the construction cost of conversion to an electric drive is low in many cases. In this series the motor shaft is rod style. So superior dynamic performance is achieved.



SERAC® XH5 and XH12
Stroke length up to 250 mm
Maximum axial force 4.5 kN to 12 kN
Max. speed 300 mm/s
More from page 22

SERAC® KH

High-rigidity construction with stable anti-rotate-device in a compact housing. Front and side mounting options for customized installation.



SERAC® KH5 to KH30
Stroke length up to 90 mm
Maximum axial/radial force ± 4.5 kN to ± 30 kN
Max. speed 320 mm/s
More from page 30

SERAC® XHM

The system technology of this screw unit, which comes with an integrated guide, is the same as for the SERAC® XH electric cylinder. Designed to fit any servo motor.



SERAC® XHM12
Stroke length up to 250 mm
Max. speed 300 mm/s
More from page 26



SERAC® LH

A fully modular structure characterises the LH series. The design with hollow shaft motor and directly driven screw nut allows long strokes to be obtained in this ultra compact electric cylinder.



SERAC® LH30 / LH50 / LH100
 Stroke length up to 330 mm
 Maximum axial force 30 kN to 100 kN
 Max. speed 425 mm/s
 More from page 34

ServoOne

The servo controls should preferably be high-performance controllers from LTI, but it is also possible to use controllers of your choice for the drive control.



ServoOne servo controller
 With DriveManager 5 PC user software
 More from page 40

The robust electric cylinder for high dynamics applications



SERAC® XH – ultra slim design

In many cases this compact electric cylinder is ideally suited for direct use instead of hydraulic cylinders.

The shaft of the torque motor is in the form of a screw at the output end, to drive the nut directly. This results in a low mass moment of inertia, giving optimum dynamic behaviour.

SERAC® electric cylinders can be operated with servo controllers from a range of well-known manufacturers. For complete, one-stop solutions, we cooperate with LTI DRIVES, manufacturer of the LTi ServoOne controller (page 42).

Short profile:

- Suitable for high dynamics applications (acceleration up to 29.4 m/s² possible)
- Low moment of inertia due to power transmission via output rod
- High control quality for rapid positioning
- Very short cycle times achieved
- Integrated locking element for smart designs
- Limit switch mountable directly on the cylinder
- SERAC® XH is available with optional holding brake

SERAC® XH5 / XH12
with directly driven output rod

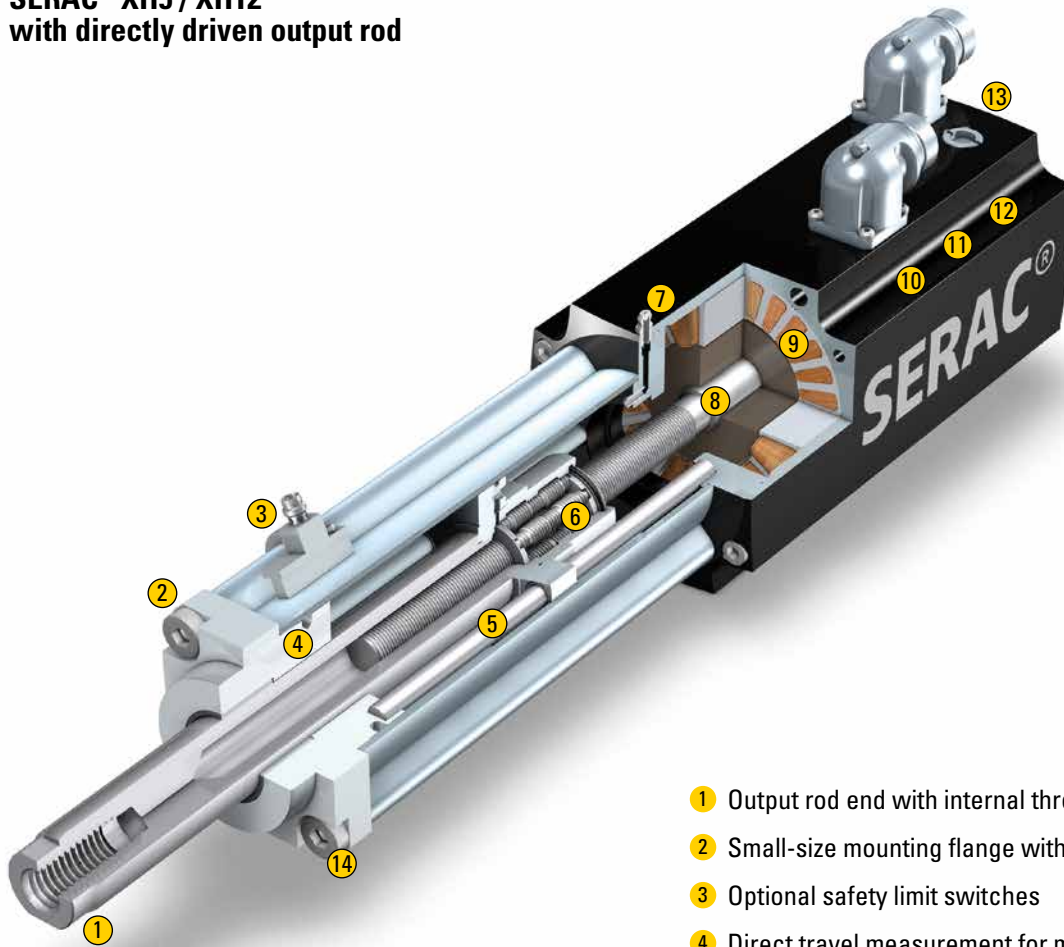

Pictured:
SERAC® XH12

- 1 Output rod end with internal thread (M16 x 32 mm)
- 2 Small-size mounting flange with internal threads
- 3 Optional safety limit switches
- 4 Direct travel measurement for maximum positioning accuracy under load
- 5 Integrated stable anti-rotation device
- 6 ASCA servo screw
- 7 Lubricating nipple for screw drive
- 8 Motor shaft and screw in one piece
- 9 Torque motor with low cogging torque
- 10 Integrated high-quality bearing
- 11 Optional inclusive integrated holding brake
- 12 Motor encoder (resolver or sin/cos 1 Vss)
- 13 Electrical connections (power and encoder connectors)
- 14 M6 internal thread for flange mounting

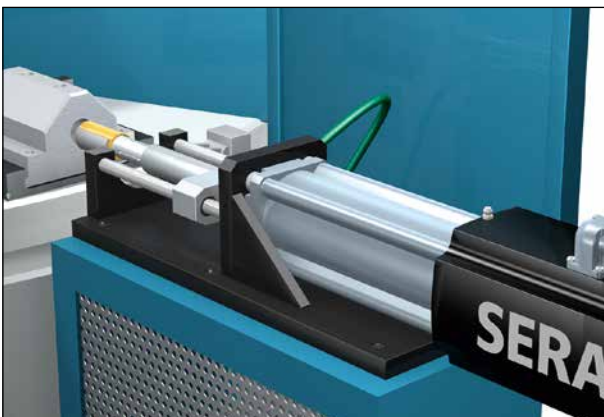

SERAC® XH5 / XH12 performance data

Model	Lead mm	Continuous force standstill *(1)		Continuous force low speed *(2)		Maximum force *(3)		Speed *(4) mm/s	Brake holding force kN	Force constant *(5) kN/A	Acceleration *(6) m/s ²
		kN	A	kN	A	kN	A				
SERAC® XH5	1	1.6	0.8	2.45	1.15	4.50	2.19	125	5.0	2.15	14.7
	2	1.0	0.8	1.45	1.15	4.29	4.00	250	2.0	1.27	29.4
SERAC® XH12	1	12.0	2.9	12.0	3.0	12.0	2.9	75	12.0	4.1	5.3
	2	8.4	3.5	12.0	5.1	12.0	5.1	150	12.0	2.4	10.6
	3	6.4	3.5	9.6	5.3	12.0	6.7	225	9.0	1.8	16.0
	4	4.8	3.5	7.2	5.3	12.0	9.2	300	7.0	1.4	21.3

¹ Continuous force at absolute standstill

² Continuous force at low speed

³ Maximum short-time force

⁴ Maximum short-time speed at continuous force

⁵ Force per ampere at low constant speed

⁶ No-load acceleration at -rated current

Screw leads from 1 to 4 mm

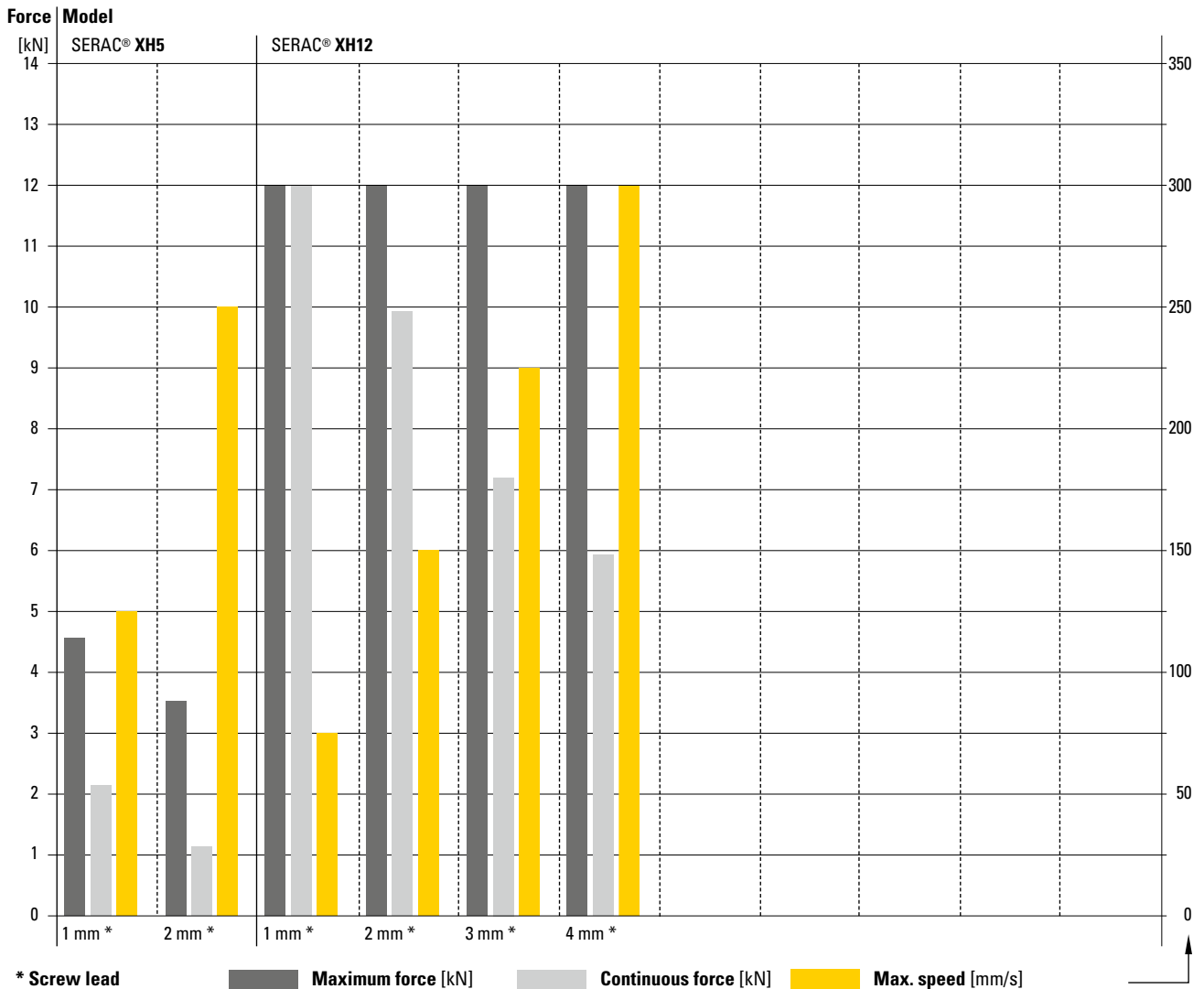

Effective values may vary. Binding values on request based on our application/specification

Model codes, dimensions and stroke lengths

SERAC® XH model codes/order data

Equipment parameter	Model specification	Order code	Series/size	
			XH5	XH12
Stroke	50 mm		050	050
	100 mm		100	100
	150 mm			150
	200 mm			200
	250 mm			250
Screw lead	1 mm		1	1
	2 mm		2	2
	3 mm			3
	4 mm			4
Brake	0 = No brake	C	0	0
	1 = Holding brake 24 VDC	C	1*	1
Motor encoder	1 = Resolver, 2-pole	D	1	1
	2 = sin/cos 1 Vss	D	2	
	3 = Hiperface			3
Linear encoder	0 = No linear encoder	E	0	0
	1 = Direct travel measurement, incremental, sin/cos 1 Vss	E	1	1
	2 = Direct travel measurement, incremental, RS422	E	2	2
	3 = Direct travel measurement, SSI absolute	E		3
Mounting	1 = Front flange mounting	H	1	1
	2 = Swivel bearing in motor area	H	2	2

* On SERAC® XH5 models with resolver the holding brake feature (C1) is not available

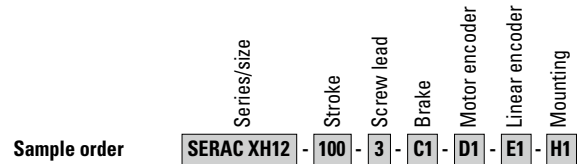

Dimensions and stroke lengths

Model	Stroke (H)	Length (L) *
SERAC XH5-050...C0	50	222
SERAC XH5-100...C0	100	272

* Models with brake (C1) are 15 mm longer



Typ	Stroke (H)	Length (L) *	
		E0 / E1 / E2	E3 (SSI absolute)
SERAC XH12-050...	50	328	378
SERAC XH12-100...	100	378	428
SERAC XH12-150...	150	428	478
SERAC XH12-200...	200	478	528
SERAC XH12-250...	250	528	578

* Both models with and without brake (C0, C1) have same length

All dimensions in mm



Ready-to-attach, high-rigidity screw unit

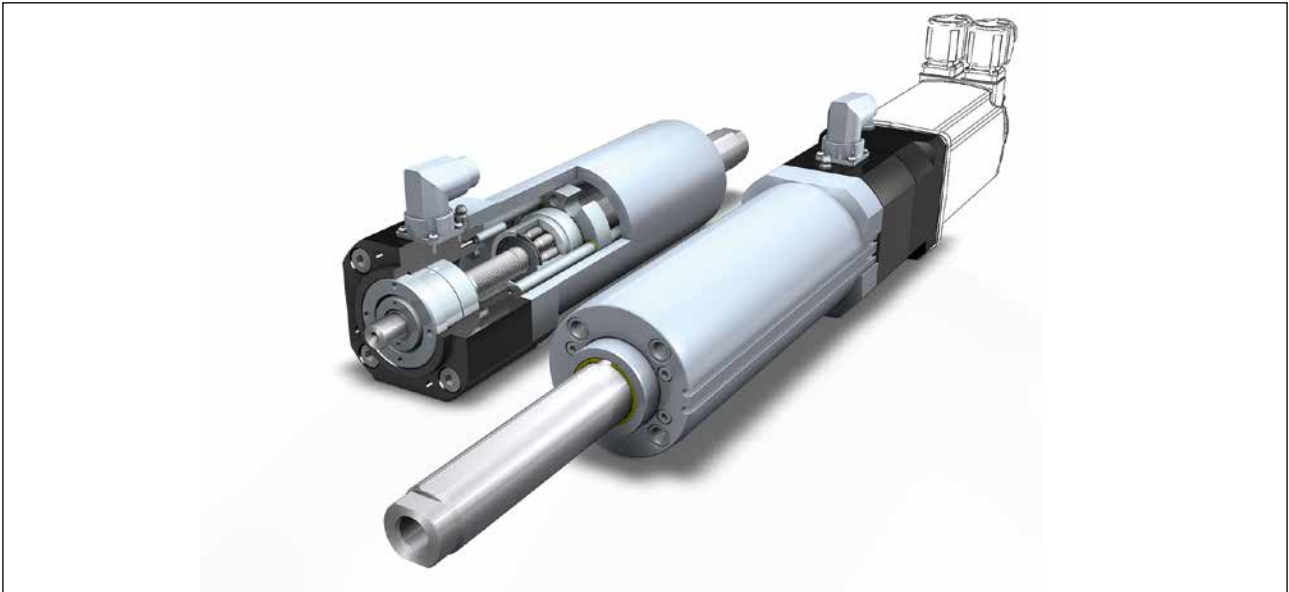

SERAC® XHM – screw unit with integrated guide and travel measurement

The system technology of this screw unit, which comes with an integrated guide, is the same as for the SERAC® XH electric cylinder. The adapter flange was designed to fit most common makes of servo motors.

Very high forces can be achieved with relatively small motors starting from a screw lead of 1 mm.

Short profile:

- Forces up to 12 kN
- Screw leads 1 mm and higher
- High rigidity
- Integrated direct travel measurement
- Zero backlash
- Smooth running
- High load capacity also with small screw leads (e.g. 1 mm)
- Long life
- Maintenance-free or low maintenance
- Torsion-resistant servo clutch

Motormontage

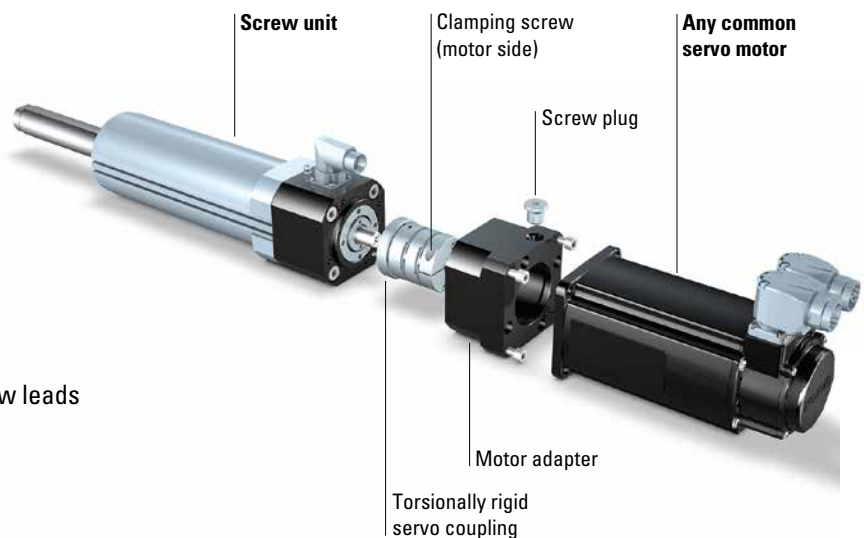

SERAC® XHM12
Screw unit with integrated anti-rotation device and travel measurement

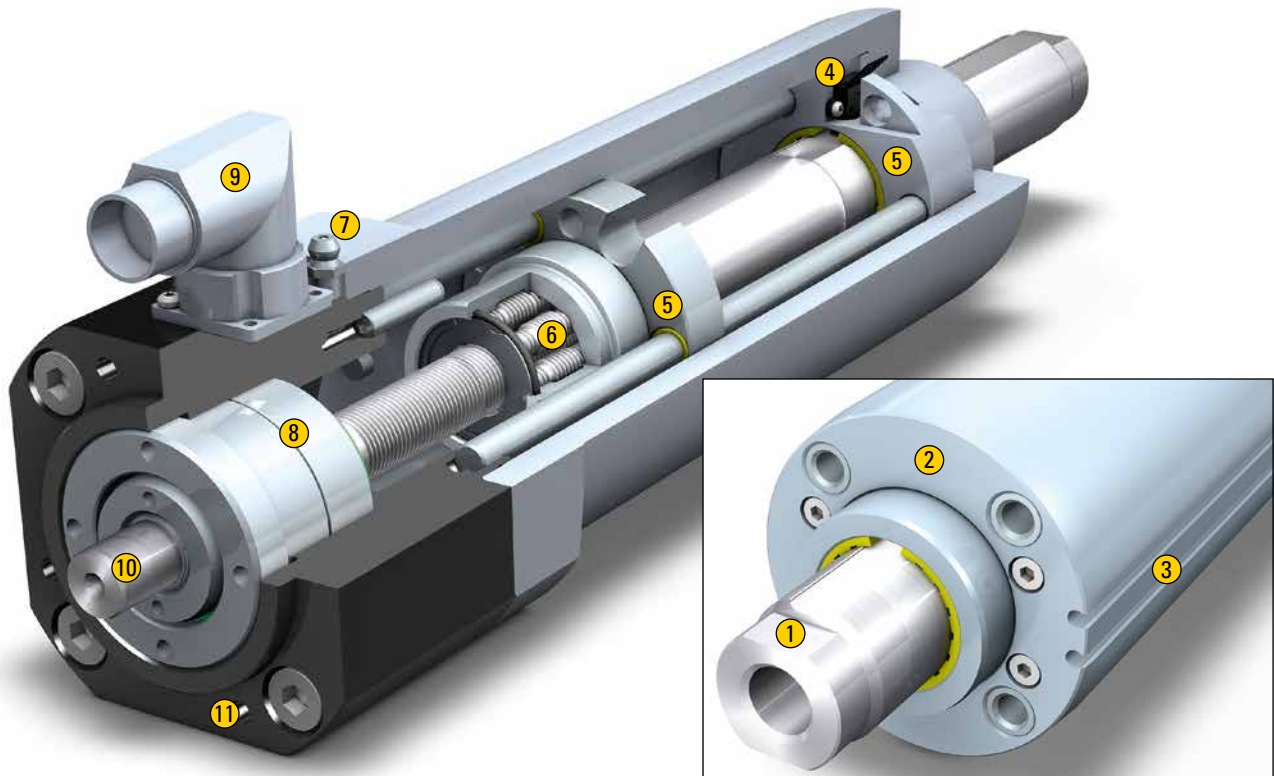

- 1 Output rod end with internal thread (M16)
- 2 Mounting flange with tapped holes (M8)
- 3 Optional safety limit switches
- 4 Direct travel measurement for maximum positioning accuracy under load
- 5 Integrated stable anti-rotation device
- 6 ASCA servo screw
- 7 Lubricating nipple for ASCA servo spindle
- 8 Play-free bearing assembly
- 9 Electrical connection (travel measurement)
- 10 Shaft end for motor coupling
- 11 Tapped hole for motor adapter

SERAC® XHM performance data

Model	Lead mm	Screw drive	Maximum load ¹ kN	No-load torque ² Nm	Torque/ force ³ Nm/kN	Max. torque ⁴ Nm	Max. speed ⁵ U/min	Speed ⁶ mm/s
SERAC®	1	PWG 16x1	12.0	0.3	0.27	3.5	8000	75
	2	PWG 16x2	12.0	0.3	0.49	6.2	8000	150
XHM12	3	PWG 16x3	12.0	0.3	0.7	8.7	8000	225
	4	PWG 16x4	10.0	0.3	0.94	10.0	8000	300

¹ Maximum, active and passive load on output rods

² At low speeds

³ Driving torque required to generate axial force

⁴ Driving torque at maximum load

⁵ Maximum short-time speed

⁶ Maximum short-time speed at rated force

SERAC® XHM12 drive torque

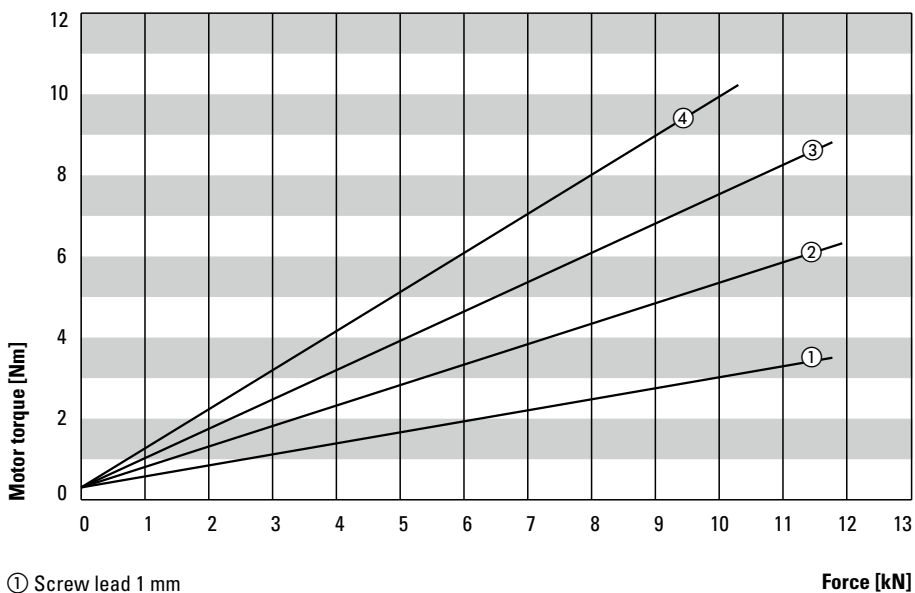

- ① Screw lead 1 mm
- ② Screw lead 2 mm
- ③ Screw lead 3 mm
- ④ Screw lead 4 mm

Force [kN]

Model codes, dimensions and stroke lengths

SERAC® XHM model codes/order data

Equipment parameter	Model specification	Order code XHM12
Stroke	50 mm	050
	100 mm	100
	150 mm	150
	200 mm	200
	250 mm	250
Screw lead	1 mm	1
	2 mm	2
	3 mm	3
	4 mm	4
Linear encoder	0 = No linear encoder	E0
	1 = Direct travel measurement, incremental, sin/cos 1 Vss	E1
	2 = Direct travel measurement, incremental, AB, RS422	E2
	3 = Direct travel measurement, SSI absolute	E3



Motor adapter

Adapter version depending on selected servo motor

Dimensions and stroke lengths SERAC® XHM12

Model	Stroke (H)	Length (L) *	
		E0 / E1 / E2	E3
SERAC XH12-050...	50	328	236.5
SERAC XH12-100...	100	378	286.5
SERAC XH12-150...	150	428	336.5
SERAC XH12-200...	200	478	386.5
SERAC XH12-250...	250	528	436.5

All dimensions in mm

* Length (L) without motor adapter

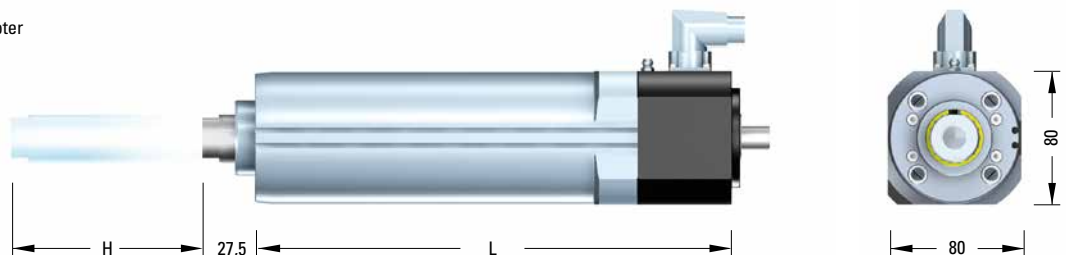

Ultra compact electric cylinder for short strokes

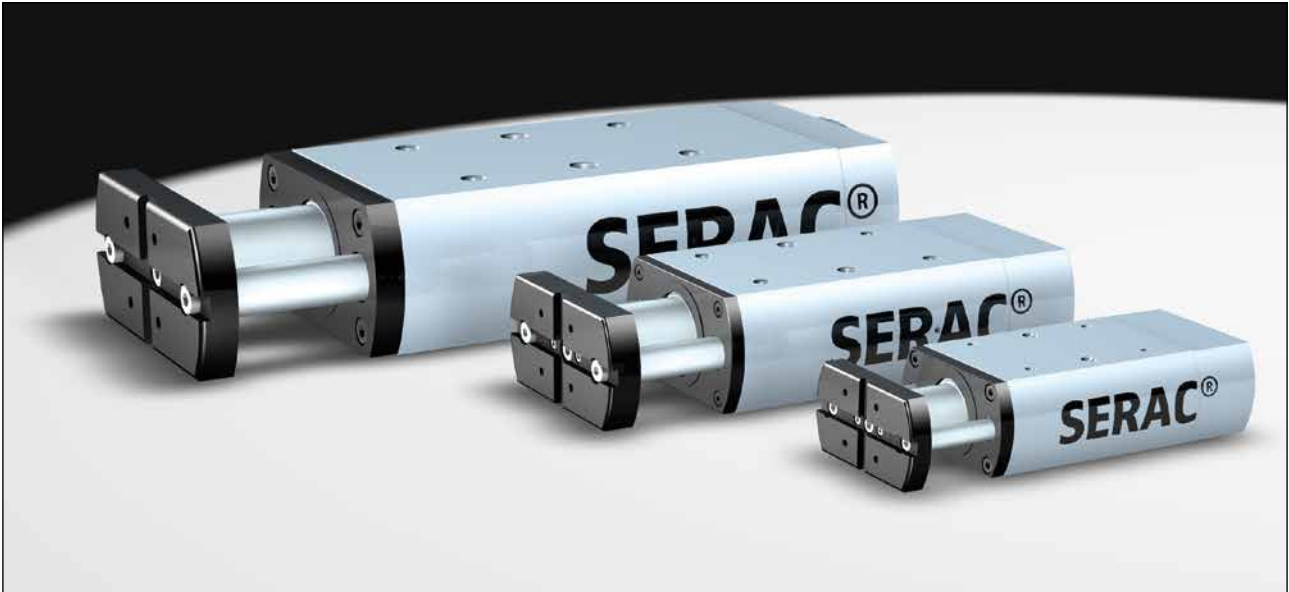

SERAC® KH – All in, all on

The striking housing design of the SERAC® KH electric cylinder is both attractive and eminently practical. All the components of this complete, preassembled drive are housed in this totally smooth housing.

Short profile:

- High rigidity construction
- Short length
- Side mounting options or flange mounting for customized installation
- Mounting option on either side offers universality and very easy installation
- Heat sink for liquid cooling (optional)
- Ideal uses: punching, sheet metal working
- Direct travel measurement for maximum positioning accuracy under load

SERAC® electric cylinders can be operated with servo controllers from a range of well-known manufacturers. For complete, one-stop solutions, we cooperate with LTI DRIVES, manufacturer of the LTI ServoOne controller (page 42).

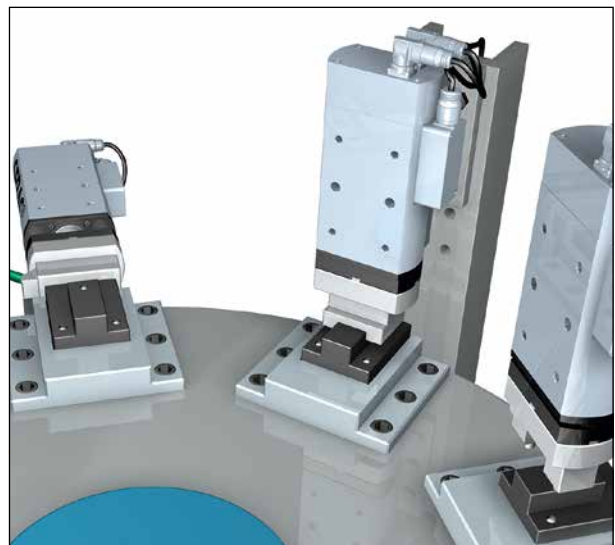

SERAC® KH5 / KH12 / KH30
with integrated anti-rotation device and travel measurement

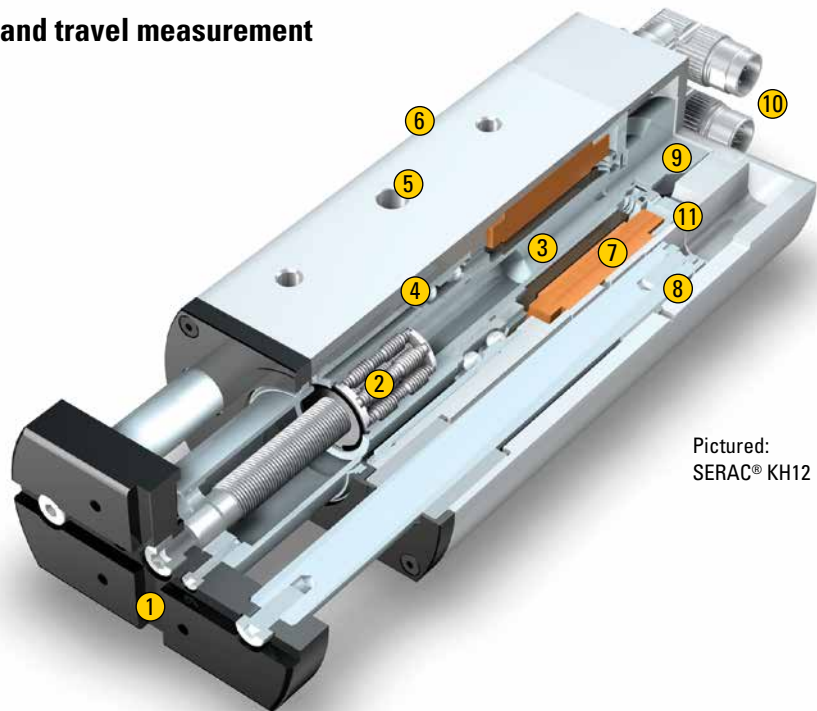

Pictured:
SERAC® KH12

Flexible in use and equipment

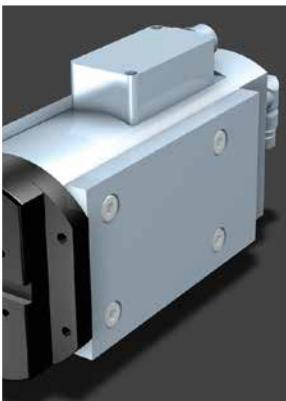

Optional liquid cooling with adaptable cooling plates to increase the continuous rating

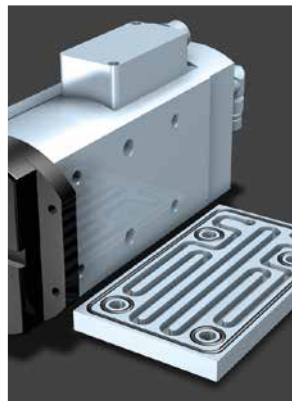

Mounting option on either side offers universality and very easy installation



The housing cover (A side) is available with optional flange version for front mounting

- 1 Grooves for exact tool positioning; asymmetrical hole pattern to ensure tool is mounted in the correct position
- 2 ASCA servo screw
- 3 Motor shaft and screw nut in one piece
- 4 High-quality bearing for very high rigidity and service life
- 5 Holes for locating pins for exact positioning and force transmission
- 6 Direct travel measurement for maximum positioning accuracy under load
- 7 Torque motor with low cogging torque
- 8 Integrated stable anti-rotation device
- 9 Motor encoder (resolver or Hiperface)
- 10 Electrical connections (power and encoder connectors)
- 11 Optional inclusive integrated holding brake

SERAC® KH5 / KH12 / KH30 performance data

Model	Lead mm	Continuous force standstill		Continuous force low speed		Maximum force		Speed *(4) mm/s	Brake holding force kN	Force constant *(5) kN/A	Acceleration *(6) m/s ²
		* (1) kN	Current A	* (2) kN	Current A	* (3) kN	Strom A				
SERAC® KH5	1	1.6	0.8	2.45	1.15	4.50	2.19	125	5.0	2.14	5.3
	2	0.9	0.8	1.36	1.15	4.02	4.00	250	3.0	1.19	10.7
SERAC® KH12	1	5.0	1.7	7.5	2.6	12.0	3.5	80	12.0	3.0	3.1
	2	3.0	1.7	4.5	2.6	10.0	6.5	160	12.0	1.8	6.2
	3	2.3	1.7	3.5	2.6	7.50	9.2	240	7.30	1.4	9.3
	4	1.8	1.7	2.6	2.6	6.00	11.8	320	5.50	1.0	12.4
SERAC® KH30	1	20.6	4.3	30.0	6.4	30.0	6.4	50	30.0	4.7	1.9
	2	12.3	4.3	18.5	6.5	30.0	10.8	100	30.0	2.8	3.7
	3	8.9	4.3	13.3	6.5	30.0	15.5	150	18.2	2.0	5.6
	4	6.7	4.3	10.0	6.5	30.0	22.0	200	13.6	1.5	7.5
	5	5.3	4.3	8.0	6.5	30.0	30.0	250	10.9	1.2	9.3

¹ Continuous force at absolute standstill

² Continuous force at low speed

³ Maximum short-time force

⁴ Maximum short-time speed at continuous force

⁵ Force per ampere at low constant speed

⁶ No-load acceleration at -rated current

Screw leads from 1 to 5 mm

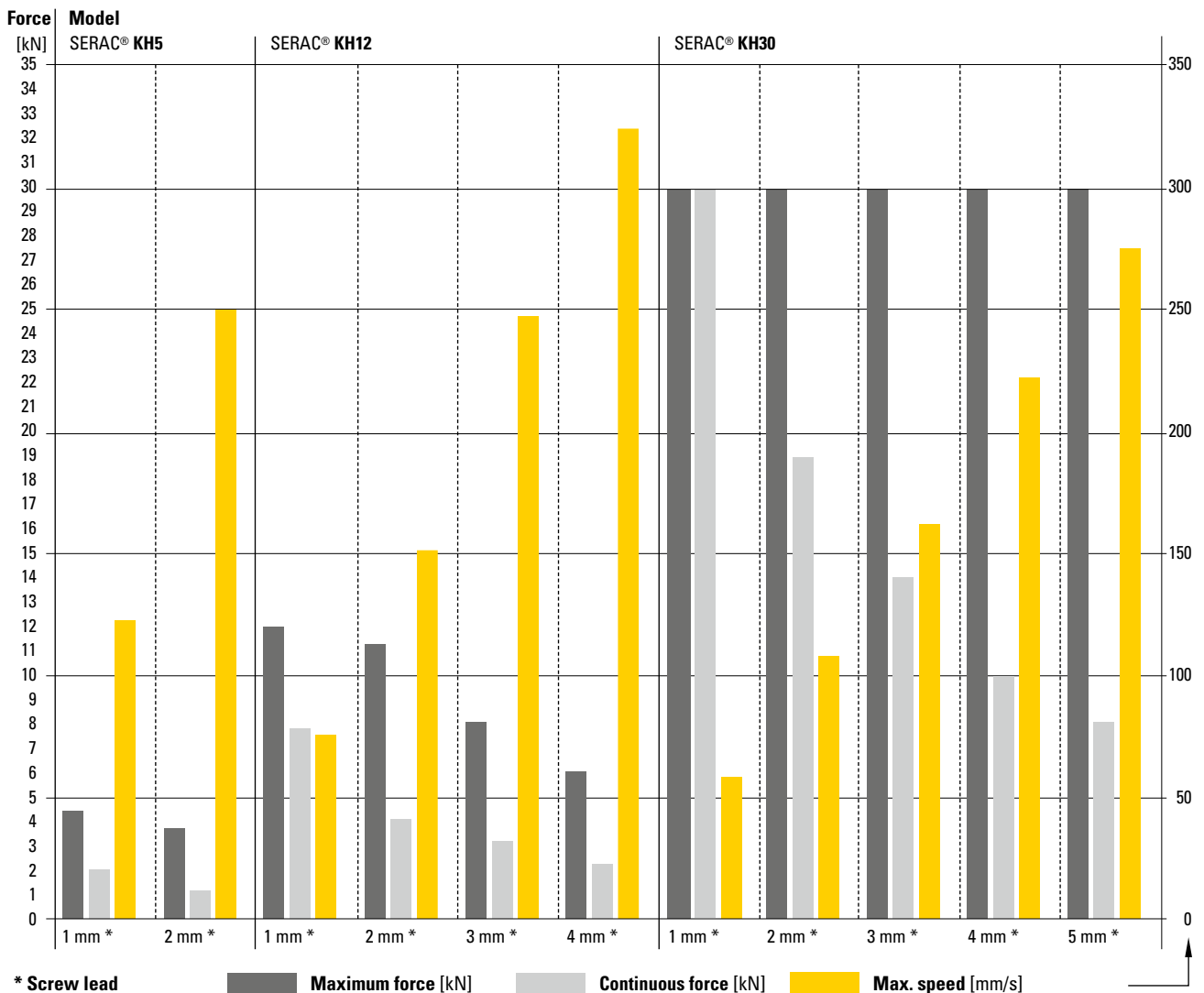

Effective values may vary. Binding values on request based on our application/specification

Model codes, dimensions and stroke lengths

SERAC® KH model codes/order data

Equipment parameter	Model specification	Order code	Series/size		
			KH5	KH12	KH30
Stroke	45 mm		45		
	65 mm			65	
	90 mm				90
Screw lead	1 mm		1	1	1
	2 mm		2	2	2
	3 mm			3	3
	4 mm			4	4
	5 mm				5
Brake	0 = No Holding brake	C	0	0	0
	1 = Holding brake 24 VDC	C	1	1	1
Motor encoder	1 = Resolver, 2-polig	D	1	1	1
	2 = Hiperface	D		2	2
Linear encoder	0 = No linear encoder	E	0	0	0
	1 = Direct travel measurement, incremental, sin/cos 1 Vss	E	1	1	1
	2 = Direct travel measurement, incremental, RS422	E	2	2	2
	3 = Direct travel measurement, SSI absolute	E		3	3
Mounting	1 = Front flange mounting	H	1	1	1
	2 = Side mounting	H	2	2	2

Series/size Stroke Screw lead Brake Motor encoder Linear encoder Mounting

Sample order **SERAC XH12** - **65** - **3** - **C1** - **D1** - **E1** - **H1**

Dimensions and stroke lengths

Model	Stroke (H)	Length (L)	
		C0	C1
SERAC KH5	45	164	204
SERAC KH12	65	245.5	302.5
SERAC KH30	90	367	437

All dimensions in mm

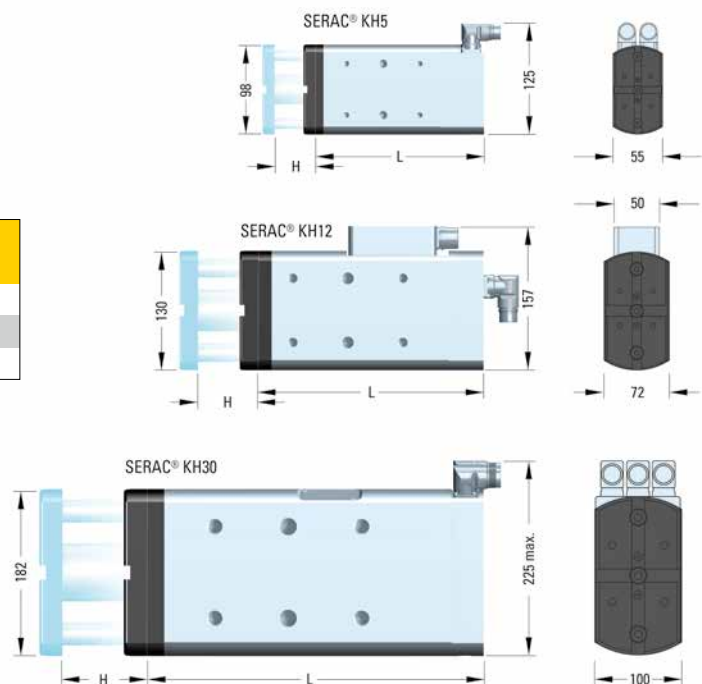

Electric cylinder with or without integrated locking element



SERAC® LH – Modular structure for a many different solutions

All the options in any combination can be selected over and above the basic LH30, LH50 and LH100 versions:

- Anti-rotate unit
- Motor holding brake
- Linear measuring system
- Different motor encoders
- Swivel bearing in motor area
- Higher protection class (IP67)
- Bellow

Some upgrade and conversion retrofits can also be carried out by us.

On this series the screw nut is driven directly by a hollow shaft torque motor.

Short profile:

- Slimline cylindrical design
- Rigid construction
- Modular construction
- Anti-rotate unit, holding brake, integrated linear travel measurement etc. optional
- Small lead (e.g. 1.5 mm) possible even at high forces (100 kN)
- Limit switch mountable directly on cylinder

SERAC® electric cylinders can be operated with servo controllers from a range of well-known manufacturers. For complete, one-stop solutions, we cooperate with LTI DRIVES, manufacturer of the LTI ServoOne controller (page 42).

SERAC® LH30 / LH50 / LH100
with high-quality bearing system for high axial loads

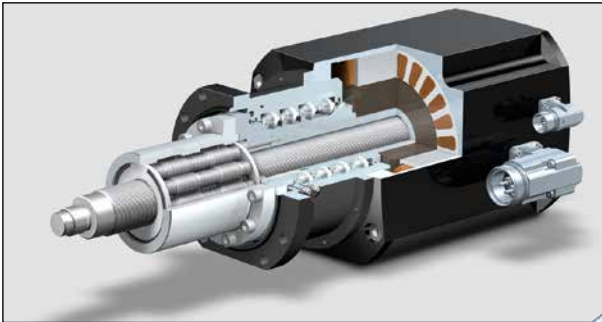

SERAC® LH100 without anti-rotate unit

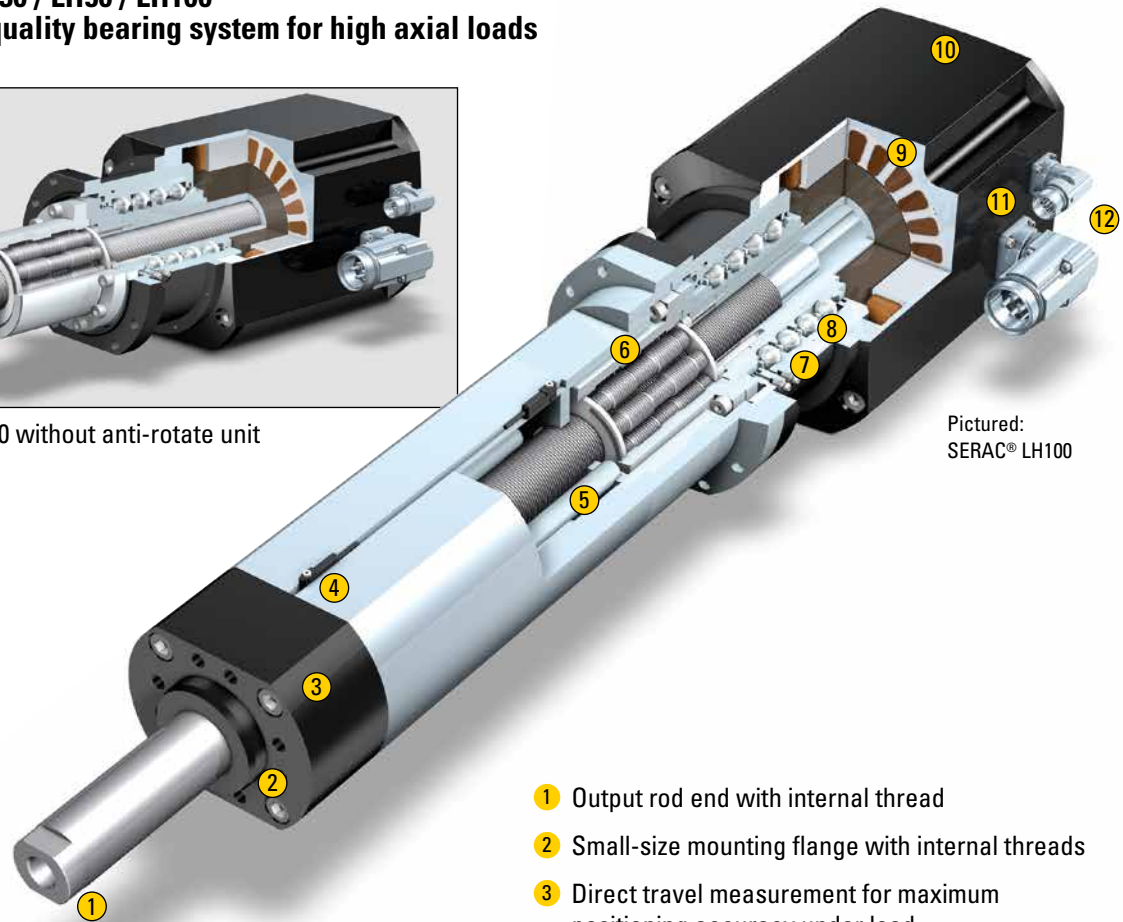

Pictured:
SERAC® LH100

- 1 Output rod end with internal thread
- 2 Small-size mounting flange with internal threads
- 3 Direct travel measurement for maximum positioning accuracy under load
- 4 Optional safety limit switches
- 5 Anti-rotation device
- 6 ASCA servo screw with directly driven screw nut
- 7 Lubricating nipple for screw and bearing system
- 8 High quality bearing system
- 9 Hollow shaft torque motor with low cogging torque
- 10 Motor encoder (resolver or Hiperface)
- 11 Holding brake
- 12 Electrical connections (power and encoder connectors)

SERAC® LH30 / LH50 / LH100 performance data

Model	Lead mm	Continuous force ¹		Maximum force ²		Speed ³ mm/s	Brake holding force kN	Force constant ⁴ kN/A	Acceleration ⁵ m/s ²
		*(1) kN	Current A	*(2) kN	Current A				
SERAC® LH30	1	30	11	30	11	85	30	2.8	1.5
	2	17	11	30	20	170	30	1.5	3.1
	3	12	11	30	28	255	25	1.1	4.6
	4	10	11	30	35	340	14	0.9	6.1
	5	8	11	30	43	425	9	0.8	7.7
SERAC® LH50	1.5	60	17	60	17	65	60	3.6	1.2
	3	37	19	60	31	130	60	2.0	2.3
	4.5	27	19	60	44	195	60	1.4	3.5
	6	22	19	60	57	260	36	1.2	4.7
SERAC® LH100	1.5	100	25	100	25	63	100	4.1	0.5
	3	60	27	100	47	125	100	2.2	1.1
	4.5	44	27	100	72	188	100	1.6	1.6
	6	35	27	100	100	250	100	1.3	2.1
	7.5	28	27	92	132	313	100	1.1	2.7

¹ Continuous force at low speed (only 2/3 thereof at complete standstill)

² Maximum short-time force

³ Maximum short-time speed at continuous force

⁴ Force per ampere at low constant speed

⁵ No-load acceleration at twice rated current

Screw leads from 1 to 7.5 mm

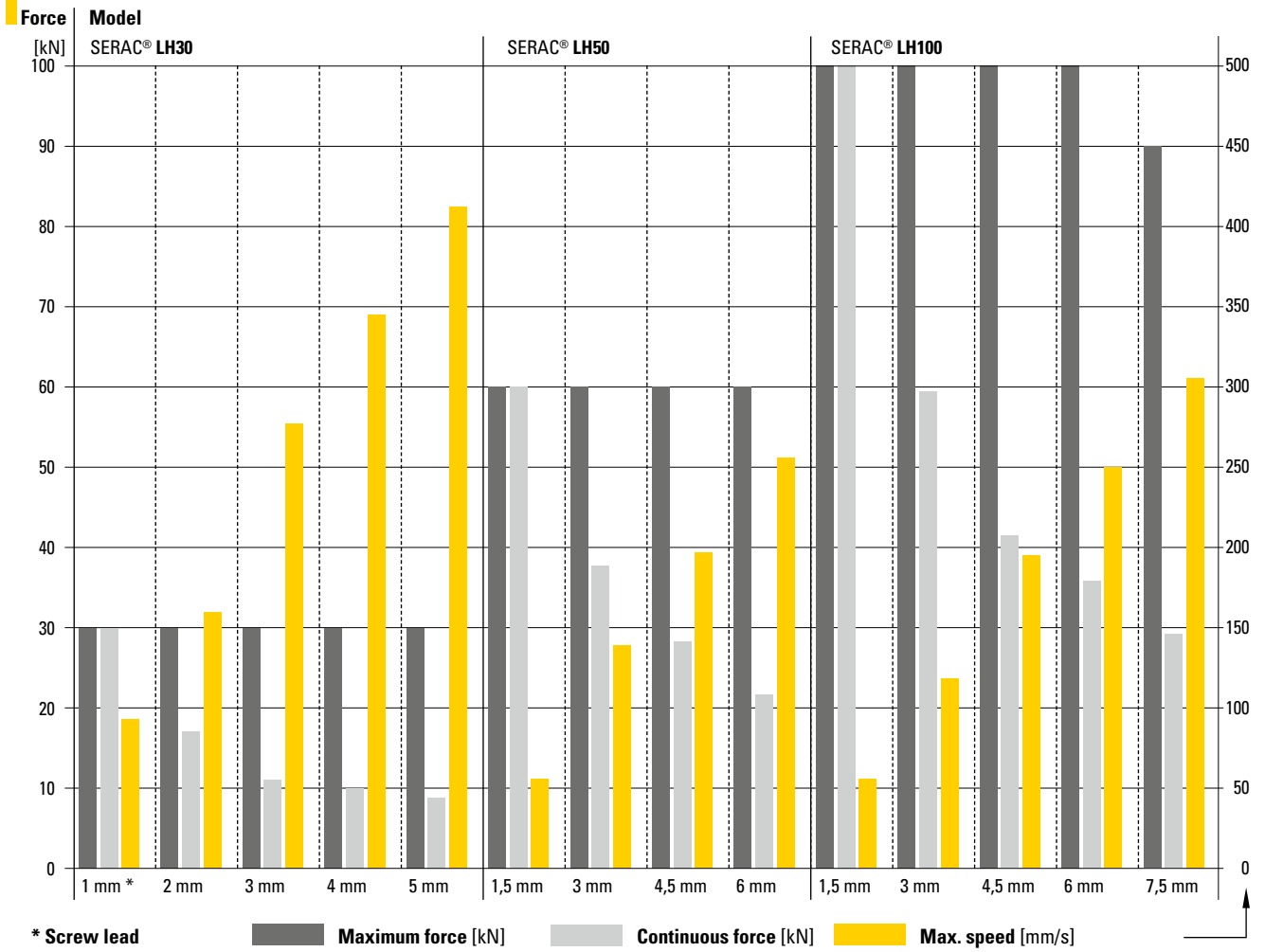

* Screw lead Effective values may vary. Binding values on request based on our application/specification

SERAC® LH model codes/order data

Equipment parameter	Model specification	Order code	Series/size		
			LH30	LH50	LH100
Stroke *	50 mm		050		
	100 mm		100	100	100
	200 mm		200	200	200
Screw lead	1 mm		1		
	1.5 mm			1.5	1.5
	2 mm		2		
	3 mm		3	3	3
	4 mm		4		
	4.5 mm			4.5	4.5
	5 mm		5		
	6 mm			6	6
Anti-rotation device	0 = Without guide or locking element	A	0	0	0
	1 = With guide and locking element	A	1	1	1
Brake	0 = No brake	C	0	0	0
	1 = Holding brake 24 VDC	C	1	1	1
Motor encoder	1 = Hiperface, single turn absolute encoder	D	1	1	1
	2 = Resolver, 2-pole	D	2	2	2
Linear encoder	0 = No linear encoder	E	0	0	0
	1 = Direct travel measurement, SSI absolute (only possible for A1)	E	1	1	1
	2 = Direct travel measurement, incremental, sin/cos 1 Vss (only possible for A1)	E	2	2	2
	4 = Direct travel measurement, incremental, RS422 (only possible for A1)	E	4	4	4
	6 = Indirect travel measurement + intermediate flange, incremental, sin/cos, 1 Vss	E	6	6	6
	7 = Indirect travel measurement + intermediate flange, incremental, RS422	E	7	7	7
Mounting	1 = Front flange mounting	H	1	1	1
	2 = Swivel bearing in motor area	H	2	2	2

* Greater strokes on request

Sample order **SERAC LH50 - 100 - 3 - A1 - C1 - D1 - E1 - H1**

Series/size
Stroke
Screw lead
Locking element
Brake
Motor encoder
Linear encoder
Mounting

Dimensions and stroke lengths

Dimensions and stroke lengths

SERAC® LH30 A0

Model	Stroke (H)	Length (L)
SERAC LH30-...-A0-C0-D1	50/100/200	300
SERAC LH30-...-A0-C0-D2		284
SERAC LH30-...-A0-C1-D1		344
SERAC LH30-...-A0-C1-D2		331.5

SERAC® LH30-A0



SERAC® LH30 A1

Model	Stroke (H)	Length (L1)
SERAC LH30-050-A1...-E1	50	196.5
SERAC LH30-050-A1...-E0, E2, E4	50	161.5
SERAC LH30-100-A1...-E1	100	246.5
SERAC LH30-100-A1...-E0, E2, E4	100	211.5
SERAC LH30-200-A1...-E1	200	346.5
SERAC LH30-200-A1...-E0, E2, E4	200	311.5

SERAC® LH30-A1

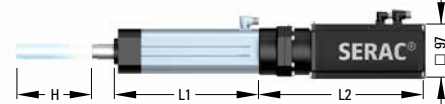

Model	Stroke (H)	Length (L2)
SERAC LH30-...-A1-C0-D1	50/100/200	300
SERAC LH30-...-A1-C0-D2		284
SERAC LH30-...-A1-C1-D1		344
SERAC LH30-...-A1-C1-D2		331.5

SERAC® LH50 A0

Model	Stroke (H)	Length (L)
SERAC LH50-100-A0-C0	100	433
SERAC LH50-100-A0-C1	100	468
SERAC LH50-200-A0-C0	200	433
SERAC LH50-200-A0-C1	200	468

SERAC® LH50-A0



SERAC® LH50 A1

Model	Stroke (H)	Length (L)
SERAC LH50-100-A1-C0	100	668.5
SERAC LH50-100-A1-C1	100	706.5
SERAC LH50-200-A1-C0	200	768.5
SERAC LH50-200-A1-C1	200	806.5

SERAC® LH50-A1



SERAC® LH100 A0

Model	Stroke (H)	Length (L)
SERAC LH100-100-A0-C0	100	489
SERAC LH100-100-A0-C1	100	550
SERAC LH100-200-A0-C0	200	489
SERAC LH100-200-A0-C1	200	550

SERAC® LH100-A0



SERAC® LH100 A1

Model	Stroke (H)	Length (L)
SERAC LH100-100-A1-C0	100	748
SERAC LH100-100-A1-C1	100	809
SERAC LH100-200-A1-C0	200	848
SERAC LH100-200-A1-C1	200	909

SERAC® LH100-A1

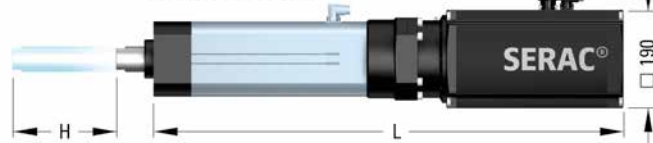

All dimensions in mm

ServoOne – die systemintegrierten Servoregler



SERAC® and ServoOne

If you prefer one-stop linear drive solutions, we can offer you pre-parametered LTI servo controllers to suit your application, in close cooperation with LTI DRIVES GmbH.

The hardware and software in the ServoOne servo controller range offer unrestricted use of the specific dynamics of the SERAC® electric cylinders.

Two series for customized solutions

The servo controllers in the ServoOne and ServoOne junior series are used.

Pictured above, left to right, are:

ServoOne junior BG2 (rated current 3.5 A)

ServoOne junior BG4 (rated current 6.5 A)

ServoOne BG1 (rated current 6 A)

ServoOne BG3 (rated current 20 A)

Other accessories for the LTI servo controller

With line chokes, brake resistors and line filters compatible with the ServoOne servo system, all the components for a complete drive package are available.

Short ServoOne profile:

- **High-speed communication**
Via popular field bus interfaces such as PROFIBUS, EtherCAT®, SERCOS II & III, PROFINET IRT, CANopen® ...
- **High-performance control**
For precise and dynamic linear motion
- **Optional integration of iPLC to IEC 61131**
Allows rapid adaptation to the actual application with direct access to the drive controller peripherals
- **Integrated functional safety**
STO (Safe Torque Off) as standard. Other functions are available as options
- **Compact size**
For optimum control cabinet utilization

PC user software and peripherals

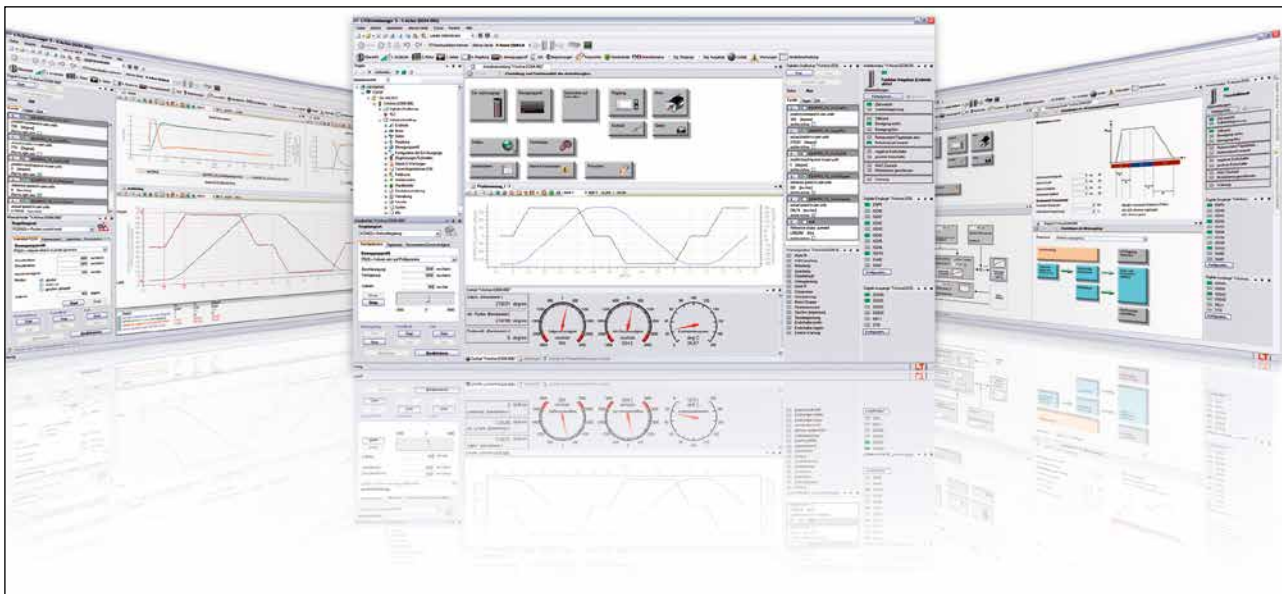

DriveManager 5

With the DriveManager PC user software, parameter adjustments and fine tuning can be carried out during commissioning. The user has access to all the main parameters.

At the same time the DriveManager with cockpit and 6-channel oscilloscope offers extremely good diagnosis options and support with project management.

Activation

The servo controller can be controlled via either the most popular field bus systems or an integrated PLC to IEC 61131 or analog and digital inputs.

Parameter set

For quick and easy commissioning of the drive, the servo controllers are equipped before delivery with a parameter set tailored to SERAC® drives. It contains the motor data, the encoder parameter settings and a basic setting for the controller.

After connection to the field bus system of the installation, the many different drive functions can then be obtained by a few adjustments to the parameter set.

New Help system

- DriveManager 5 Help
- Device Help for ServoOne single-axis system and ServoOne junior
- The Help is implemented in DriveManager 5
- It is also available separately as a chm or pdf file under Downloads

Additional accessories

Cable sets

SERAC® drives are connected to the ServoOne servo system by preassembled power and encoder cables.

Compatible cable sets for connection to many different makes of servo controller are also available.

Endswitches

The SERAC® XH and LH-range are already provided for the assembly of endswitches. Available are opener and closer inclusive cable.

Force sensor

Delivery of a suitable force sensor according to your specification.

Mechanical parts

We will gladly also supply mechanical attachments.



Ortlieb Präzisionssysteme GmbH & Co. KG
Dettinger Str. 129
73230 Kirchheim / Teck
Germany

Tel. +49 (0)7021 - 9469-0
Fax +49 (0)7021 - 9469-51
info@ortlieb.net
www.ortlieb.net